

सेंट्रलकोलफील्ड्सलिमिटेड

(कोलइंडियालिमिटेडकीएकसहायककंपनी)

एनके क्षेत्र, रांचीझारखंड-829210

ईमेल: soxnk2021.2@gmail.com

टेली:- 9438878764

Officewebsite:www.centralcoalfields.in

उत्खननविभाग



वसुधैव कुटुम्बकम्
ONE EARTH - ONE FAMILY - ONE FUTURE

CentralCoalfieldsLimited

(A Subsidiary of CoalIndiaLimited)

NK Area,Ranchi,Jharkhand-829210

e-mail:soxnk2021.2@gmail.com

tele:- 9438878764

Officewebsite:www.centralcoalfields.in

CIN No.- U10200JH1956GOI000581

ExcavationDepartment, NK Area

E-mail –soxnk2021.2@gmail.com

Website – www.coalindiatenders.nic.in

Phone: 9438878764

NIT No: GM(NK)/Excv/eTender/26-27/25

Dated: 27.05.2026

निविदा सूचना

Notice Inviting Tender

1. Tenders are invited on-line under two part system on the website <https://coalindiatenders.nic.in> from the eligible bidders having Digital Signature Certificate (DSC) issued from any agency authorized by Controller of Certifying Authority (CCA), Govt. of India and which can be traced up to the chain of trust to the Root Certificate of CCA, for the following work:

Description of work	Location	Estimated Cost of Work (Including GST) (In Rs.)	Earnest Money * (In Rs.)	Period of Completion (In Days)
Repairing of 4nos.carrier roller, rebuilding of both side trunion, rebuilding of sprocket segment replacement of track chain both side by removal of chain from other dozer, replacement of both side track roller by removal of both trolley of BD 155 Dozer sl no 13739, sl.no. T3829 (hours worked-11197) of KDH Project, NK Area	KDH OCP, NK Area	4,15,166.48	5,200.00	15 days

(i) **Salient Details of Tender:**

Input Tax Credit (ITC)	Available
Applicability of Price Variation clause	Not Applicable
Participation of Joint Venture (JV)	Not Allowed

(ii) **For Site visit of location of work, the prospective bidder(s) may contact:**

Tender inviting authority	Contact Person(s)/Tender Dealing Officer(s)
Staff Officer (Excv.), NK Area, CCL	Phone No. 9438878764

(III)

Scope of Work/Technical Specification etc-						
Sl.no.	Activities including all material , labour , tools & tackles and plant all complete to the satisfaction of Engineer-In – Charge	Schedule	Material Required	Labour Required	Contractor Scope	CCL Scope
1.	Making HEMM Available for Repair work	NA	NA	NA	NO	YES
2.	Providing of crane whenever required till recommissioning of dozer	NA	NA	NA	NO	YES
3.	Removal of blade assly by removing of both side arm.	1 shift	NA	Supervisor ,Fitter, Helper Etc	Tools and Manpower	NO
4.	Proper jacking/lifting of complete machine for removal of track chain, track frame etc	1 shift	NA	Supervisor ,Fitter, Helper Etc	Tools and Manpower	NO
5.	Both side track chain removal by removal/ cutting of lock of master pin.	2 shifts	Tools,Puller,welding and gauging electrode, etc	Supervisor,welder,fitter,helper etc.	YES	NO
6.	Removal of 04 nos carrier roller from track frame	½ shift	Tools , tackles	Supervisor ,Fitter,Helper Etc	YES	NO
7.	Repairing of 04 nos carrier roller by deposition of suitable material by welding and make proper size by cutting and grinding	8 shifts	Welding electrode, Grinding disc, Grinding M/C , Cutting tool	Supervisor, Machinist, welder,fitter,helper etc.	YES	NO
8.	repairing of both side trunion assly	8 shifts	Welding electrode, Grinding disc, Grinding M/C , Cutting tool	Supervisor,Machinist, welder,fitter,helper etc.	YES	NO
9.	Removal of both side sprocket segment	2 shifts	NA	Supervisor ,Fitter,Helper Etc	Tools and Manpower	NO
10.	Repairing and re-building pf all sprocket of both LHS and RHS	12 shifts	Welding electrode, Grinding disc, Grinding M/C , Cutting tool	Supervisor,Machinist, welder,fitter,helper etc.	YES	NO
11.	Removal of track chain from survey of machine	2 shifts	Tools , tackles	Supervisor ,Fitter,Helper Etc	YES	NO
12.	Removal of all track roller from both side track chain and fitment of serviceable roller in track frame	8 shifts	Tools , tackles	Supervisor ,Fitter,Helper Etc	YES	NO
13.	fitment of repaired sprocket in both side	2 shifts	NA	Supervisor ,Fitter,Helper Etc	Tools and Manpower	NO
14.	Fitment of repaired track roller in both side track frame	1 shift	NA	Supervisor ,Fitter,Helper Etc	Tools and Manpower	NO
15.	Fitment of both side track frame in the machine	4 shifts	NA	Supervisor ,Fitter,Helper Etc	Tools and Manpower	NO
16.	Fitment of track chain assly in both side track frame.	2 shifts	NA	Supervisor ,Fitter,Helper Etc	Tools and Manpower	NO
17.	Fitment of blade and arm assly in trunion.	2 shifts	NA	Supervisor ,Fitter,Helper Etc	Tools and Manpower	NO
18.	Drinking water, Power supply(if Required)	NA	NA	NA	NA	YES

1. Dismantling of both side chain and opening of 4 nos carrier roller. Removal of both side sprocket segment. Welding of carrier roller as per standard size. Rebuilding of all sprocket segment as per standard size. And fitment of carrier roller, and sprocket segment and assembling of both side track chain.
2. Removal of both side blade arm and rebuilding of both side trunion by welding and grind as per standard size. Fitment of both side arm.
3. Removal of both side track chain by other grounded dozer and fitment in 13739 dozer.
4. Removal of both side trolley and fitment of carrier roller. Fitment of both side trolley in the machine.
5. Testing of machine for proper fitment , if and correction required for proper functioning may also to be done by bidder.

All accessory and transportation other than Electric Power, Crane, and water will be in bidder's Scope.

Specific requirement from bidder:

- Arrangement of required manpower (skilled welder, fitter, helper, machinist, supervisor)
- Welding electrodes (Lomelt 210) or similar- 5 mm,
- Threading tool- 22 mm
- Cutting tool- 12 x 75 mm
- Grinding machine and Grinding discs 4"
- Drill machine and Drilling tool 20mm

2. Time Schedule of Tender:

Sl. No	Particulars	Date	Time
a.	Tender e-Publication date	27.05.2026	18:00 Hrs
b.	Document download start date	27.05.2026	18:00 Hrs
c.	Document download end date	08.06.2026	18:00 Hrs
d.	Bid Submission start date	27.05.2026	18:00 Hrs
e.	Bid submission end date	12.06.2026	18:00 Hrs
f.	Start date for seeking Clarification on-line	27.05.2026	18:00 Hrs
g.	Last date for seeking Clarification on-line	08.06.2026	18:00 Hrs
h.	Technical Bid (Cover I) opening date	13.06.2026	11:00 Hrs
i.	Price Bid (Cover II) opening date	To be communicated to successful bidder via portal	

Note: The auto extension of submission of bid shall be applicable as per details mentioned in clause No.14 of NIT.

3. Earnest Money Deposit(EMD):

The bidder will have to make the payment of EMD through ONLINE mode only.

3.1 In Online mode the bidder can make payment of EMD either through **NET-BANKING** from designated Bank(s) or through **NEFT/RTGS** from any scheduled Bank(s).

NET-BANKING: In case of payment through net-banking the money will be immediately transferred to CIL/ Subsidiary's designated Account.

NEFT/RTGS: In case of payment through NEFT/RTGS from any scheduled bank(s), the bidder will have to make payment as per the Challan(s) generated by system on e-Procurement portal. The payment of EMD through NEFT/RTGS mode should be made well ahead of time to ensure that the EMD amount is transferred to CIL/ Subsidiary account before submission of bid.

3.1.1 The Bidder will be allowed to submit his/her/their bid only when the EMD is successfully received in CIL/ Subsidiary's designated account and the information flows from Bank to e-Procurement system.

3.1.2 In online payment of EMD, if the payment is made by the bidder within the last date and time of bid Submission but not received by CIL/ Subsidiary within the specified period due to any reason(s) whatsoever then the bid will not be accepted. However, the EMD will be refunded back to the bidder.

3.1.3 Micro and Small Enterprises (MSEs) as defined in MSE Procurement Policy issued by Department of Micro, Small and Medium Enterprises (MSME) will be exempt from the payment of earnest money (*applicable only for Services tenders*).

In case of exemption of EMD, the scanned copy of document (attested by notary public) in support of exemption will have to be uploaded by the bidder during bid submission. However, this option is to be enabled only in those cases where the exemption of EMD to some bidders is allowed as per NIT.

4. Pre-bid Meeting:

The pre-bid meeting if applicable shall be held in the office of Tender Inviting Authority, on the scheduled date & time, if specified in the NIT. The purpose of the pre-bid meeting is to clarify the issues and to answer the questions on any matter that may be raised at that stage. Non-attendance at the pre-bid meeting will not be a cause for disqualification of bidder and it shall be presumed that the bidder does not require any clarification. The management shall circulate proceedings of the pre-bid meeting, if held.

5. Clarification of Bid:

The bidder may seek clarification on-line within the specified period. However, the management will clarify as far as possible to the relevant queries.

6. User Portal Agreement:

The bidders have to accept the on-line user portal agreement which contains the acceptance of all the Terms and Conditions of NIT and tender document, undertakings, the letter of bid and the e-Procurement system through <https://coalindiatenders.nic.in> in order to become an eligible bidder. This will be a part of the agreement.

7. Eligible Bidders:

The invitation for bid is open to all bidders including an individual, proprietorship firm, partnership firm, company, Joint Venture having eligibility to participate as per eligibility cri-

teria stipulated in clause No.8 of NIT and having Digital Signature Certificate (DSC) issued from any agency authorized by Controller of Certifying Authority (CCA), Govt. of India and which can be traced up to the chain of trust to the Root Certificate of CCA.

Note: Joint Venture shall not be allowed for participation in the bid with estimated cost of work put to tender up to Rs. 2.00 (two) crores.

8. Eligibility Criteria:

A. Work Experience:

The Intending bidder must have in its name or proportionate share as a member of Joint Venture/Partnership firm experience of having successfully **completed similar** works during last 7(seven) years ending last day of month previous to the one in which bid applications are invited (i.e. eligibility period) should be any of the following :-

Three similar **completed works** each costing not less than the amount equal to 40% of the estimated cost put to tender.

Or

Two similar **completed works** each costing not less than the amount equal to 50% of the estimated cost put to tender.

Or

One similar **completed work** costing not less than the amount equal to 80% of the estimated cost put to tender.

Experience for those works only shall be considered for evaluation purposes, which match eligibility requirement stipulated above, on or before the last day of month previous to one in which tender has been invited (publication date of NIT). The experience of incomplete/ongoing works as on last date of eligibility period will not be considered for evaluation. If the referred work includes construction/Erection & commissioning/Installation as well as maintenance and/ or operation after construction/Erection & Commissioning/Installation, the experience of such work may be considered as 'acceptable' if the construction/Erection & Commissioning/Installation part is completed as on the last date of 'eligibility period', even if maintenance work is ongoing, and the certificate issued clearly stipulates the same.

In all the above cases, while considering the value of completed works, the full value of completed work be considered whether or not the date of commencement is within the said 7(seven) years period. The date of completion of work should be during last 7(seven) years ending last day of month previous to the one in which bid applications are invited.

Cost of previous completed works shall be given a simple weightage of 7% per year to bring them at current price level, while evaluating the qualification requirement of the Bidder. Such weightage shall be considered after end date of completion. Updating will be considered for full or part of the year (total no. of days / 365) i.e. considering 365 days in a year, till the last day of month previous to one in which bid has been invited.

Joint Venture shall be allowed for participation in the bid with estimated cost above Rs. 2.0 Crores.

~~The above qualification criteria shall be fulfilled by JV in the following manner:~~

~~The qualifying criteria parameter e.g. experience of the individual partners of the J.V will be as deliberated hereinafter towards fulfilment of qualification criteria related to experience.~~

~~a) In case of completion of single work of similar nature costing, not less than the amount equal to 80% of the estimated cost put to tender:-~~

~~Any of the JV partner/JV itself shall have the experience of having completed successfully a single work of similar nature equal to 80% of the estimated cost put to tender.~~

~~Or~~

~~b) In case of completion of two works of similar nature each costing not less than the amount equal to 50% of the estimated cost put to tender :-~~

~~i) Either the JV itself/ Any one partner can match the above requirement.~~

~~—————Or~~

~~ii) At least two partners should each have completed at least one work of similar nature each costing not less than the amount equal to 50% of the estimated cost put to tender.~~

~~Or~~

~~c) In case of completion of three works of similar nature, each costing not less than the amount equal 40% of the estimated cost put to tender:-~~

~~i) Either the JV itself/ Any one partner can match the above requirement.~~

~~—————Or~~

~~ii) Any two partners shall match the above requirement through completion of at least two work by one partner and one work by other partner of similar nature each costing not less than the amount equal 40% of the estimated cost put to tender.~~

~~—————Or~~

~~iii) All the three partners shall match the above requirement through completion of at least one work of similar nature each costing not less than the amount equal 40% of the estimated cost put to tender.~~

~~————The above qualification criteria shall be met collectively by JV partners or JV itself.~~

~~If a Bidder participates as a Joint Venture (JV), the benefits as per Public Procurement Policy for MSEs order — 2012 shall not be applicable for them.~~

~~The qualifying criteria parameter e.g. experience of the individual partners of the JV will be added together towards fulfilment of qualification criteria related to experience.~~

The definition of similar work shall be as follows:

“Firm should have experience of repairing / re-building / re-conditioning work by welding process and /or machining of any HEMM or any Auxiliary equipment (like water sprinkler, crane, tyre handler etc) or its assemblies / sub-assemblies / parts., or combination of above.

OR

Firm should have experience of Fabrication & Fitment/ Body Repair Work of HEMM or any

Auxiliary equipment (like water sprinkler, crane, tyre handler etc.)

OR

Firms having experience of CAMC (Comprehensive Annual Maintenance Contract) for HEMM."

In respect of the above eligibility criteria the bidders are required to furnish the following information on-line:

Data to be furnished by the Bidders:

- i. Description of qualifying experience (Similar nature)
- ii. Work order Number /Agreement Number of each experience
- iii. Name & address of Employer/Work Order Issuing authority of each experience
- iv. Percentage (%) share of each experience (In case the experience has been earned by the Bidder as a partner in a Joint Venture firm/Partnership firm then the proportionate value of experience in proportion to actual share of Bidder in that Joint Venture firm/ Partnership firm will be considered against eligibility else it shall be taken as 100%).
- v. Executed Value of work against each experience
- vi. Start date & end date of each qualifying experience (similar nature)

Note:-

- a. In case the Bidder is a Joint Venture, work experience as above may be furnished as the work experience of the Bidder.
- b. Confirmation in the form of Yes/No regarding submission of similar work experience as defined in the NIT.

Scanned copy of documents to be uploaded by Bidders (CONFIRMATORY DOCUMENT):

For work experience Bidders required to submit Satisfactory Work Completion Certificate issued by the employer against the Experience of similar work containing all the information as sought on-line.

Work order, BOQ, TDS etc. may be sought during clarification or along with deficient documents, if felt necessary by the Tender Committee.

Technical evaluation by the System:

- i. The system shall calculate the period of 7 years backwards starting from the last day of month previous to the e-Publication date of NIT.
- ii. The system shall check the End date of each experience (The system shall not allow more than 3 entries for experience) and accept it as a qualifying experience if the end date of experience falls within the 7 years computed by the system.
- iii. The system shall calculate the value of each qualifying experience by multiplying the value with the % share of experience and adding 7% for each completed year (total No. of days/365) after the end date of experience of work till the last date of month previous to one in which the NIT has been published on e-Procurement portal.

iv. The system shall check the experience with highest value whether it exceeds 80% of ECV. In case it does not, it shall check the top 2 experiences whether each of them is greater than 50% of ECV. In case, it still does not, the system shall check all 3 qualifying experiences whether each of them exceeds 40% of ECV. The system shall regard the Bidder as 'Eligible' if it meets any of the aforementioned criteria or else it shall consider the Bidder as 'Ineligible'.

v. The weightage of 7% every year will be on simple rate and will not be compounded on yearly basis for the purpose of calculating the value of each qualifying experience.

vi. The work experience of the Bidder for those works only shall be considered for evaluation purposes, which are completed before the last date of month previous to one in which NIT has been published on e-Procurement portal. Hence, the works which are incomplete/ ongoing, as on the last date of month previous to one in which NIT has been published on e-Procurement portal, shall not be considered against eligibility.

vii. In case the work is started prior to the eligibility period of 7 years (counted backwards starting from the last day of month previous to the e-Publication date of NIT) and completed within the said eligibility period of 7 years, then the full value of work shall be considered against eligibility.

viii. In case the experience has been earned by the Bidder as an individual or proprietor of a proprietorship firm, then 100% value of the experience will be considered against eligibility. But if the experience has been earned by the Bidder as a partner in a Joint Venture/ Partnership firm then the proportionate value of experience in proportion to the actual share of Bidder in that Joint Venture/ Partnership firm will be considered against eligibility.

B. Financial Turnover: Average annual financial turnover during the last 3 (three) years ending 31st March of the previous financial year should be at least 30% of the estimated cost put to tender. (Financial Turnover criteria is not applicable for tenders with ECV below 50 lakh)

(The "Previous Financial Year" shall be computed with respect to the e-Publication date of NIT).

If any bidder does not furnish the turnover value for any financial year out of the last 3 financial years, the turnover for that financial year shall be taken as 'Zero' and the average annual financial turnover shall be calculated accordingly.

Financial turnover shall be given a weightage to bring them at current price level by adding 7% for each completed year (total number of days/365) after the end of respective financial year (i.e. 31st March) till the last day of month previous to one in which e-tender has been invited.

Joint Ventures shall meet the above eligibility requirement, in the following manner:

The qualifying, criteria parameter e.g. financial resources (Turnover) of the individual partners of the J.V. will be added together, for the relevant financial year, and the total should not be less than as spelt out above. The requirement of Turnover under this clause shall be met in the proportion given below:

- a. The lead partner shall have at least 50% share in the required Average Financial Turnover, to qualify in the tender.
- b. All other individual partners shall have at least 25% share in the required Average Financial Turnover, to qualify in the tender.

(In case of JV, Turnover certificate for each individual partners of JV)

In respect of the above eligibility criteria the bidders are required to furnish the following information on-line :

- i) Annual turnover of each of the last 3 (three) years ending 31st March of the previous financial year.
- ii) Name of the Chartered Accountant issuing the Profit and Loss A/c or the Turnover certificate.
- iii) Membership Number of the Chartered Accountant.
- iv) Date of certificate issued by Chartered Accountant.
- v) Confirmation regarding possessing of Financial Turnover issued by a Practicing Chartered Accountant in the form of Yes / No.

Note:

a. In case the bidder is a Joint Venture, the turnover of the individual partners of the JV will be added together for each financial year and is to be furnished as the turnover of the bidder for that particular financial year. However, the information against Sl.No.(ii) & (iv) above will be given w.r.t. the lead partner of JV only.

Scanned copy of documents to be uploaded by bidders:

Financial Turnover certificate having a Unique Document Identification Number (UDIN) with Institute of Chartered Accountants of India.

- C. Permanent Account Number(PAN) :** The Bidder should possess a valid permanent account number issued by Income tax Department, Govt of india.

In respect of the above eligibility criteria the bidders are required to furnish the following information on-line :

- i) Confirmation regarding possessing of Permanent Account Number(PAN) issued by Income Tax department, Govt. of India in the form of Yes / No.

Scanned copy of documents to be uploaded by Bidders (BIDDER SPACE/ MY DOCUMENT) :

PAN CARD of the Bidder

Note : In case of JV, PAN card for each Indian partner of JV and Verifiable Tax Residency Certificate of respective country for each foreign partner or JV itself.

D. Goods and Services Tax (Not Applicable for Exempted Services)

The bidder should be either GST Registered Bidder under regular scheme

OR

GST Registered Bidder under composition scheme

OR

GST unregistered Bidder

In respect of the above eligibility criteria the bidder is required to furnish the following information online:

i). Confirmation in the form of Yes/No regarding possessing of required document as enlisted in NIT with respect to GST status of the bidder.

Scanned copy of documents to be uploaded by bidder(s) in Bidder space/ My Document.

Document as per 9(a) (iii) below.

Note:

i). In case of JV, In case of JV, Bidder should submit scanned copy of GST status of Lead Partner only or GST Registration Certificate of JV itself.

ii). In case the work/service is awarded to a Joint Venture participating in the tender they have to submit PAN, GST registration (as applicable in the tender and for the bidder status) etc. in the name of the Joint Venture after Award of Work/Service before the payment of first running on account bill.

iii) If turnover of bidder exceeds exemption/threshold limit, the bidder must have GST registration as per GST Act and rules.

iv) During the execution of the contract if the GST status of the bidder changes, then the payment of GST, if any, to the contractor will be made as per the GST status declared by the bidder during tender stage based on which cost to company has been ascertained or at actuals, whichever is lower.

Scanned copy of documents to be uploaded by bidder(s) in support of information / declaration furnished online by the bidder against Eligibility Criteria as Confirmatory Document.

E. Purchase Preference under 'Make in India' Policy for "Local supplier". (NOT APPLICABLE WHERE ESTIMATED COST PUT TO TENDER IS LESS THAN 5 LAKHS.)

Preference to Make in India (as applicable) vide Order No. P-45021/2/2017-PP (BE-II) dated 16.09.2020, issued by Govt. of India as amended from time to time shall be applicable.

In terms of the above said policy, purchase preference shall be given to Class-I local supplier.

In terms with the above said policy, Class-I local suppliers and Class-II local suppliers shall be eligible to bid. The definitions of Class-I Local Supplier, Class-II local supplier, Non-Local supplier, Local Content and Margin of Purchase Preference as per above mentioned Order are as follows:

A. 'Class-I local supplier' means a supplier or service provider, whose goods, services or works offered for procurement, has local content equal to or more than 50%, as defined under said order.

B. 'Class-II local supplier' means a supplier or service provider, whose goods, services or works offered for procurement, has local content equal to or more than 20% but less than 50%, as defined under said order.

- C. 'Non-Local supplier' means a supplier or service provider, whose goods, services or works offered for procurement, has local content less than 20% as defined under said order.
- D. 'Local Content' means the amount of value added in India which shall be the total value of the item procured (excluding net domestic indirect taxes) minus the value of imported content in the item (including all customs duties) as a proportion of the total value, in percent.
- E. 'Margin of Purchase Preference' means the maximum extent to which the price quoted by a Class-I local supplier may be above the L1 for the purpose of purchase preference. The margin of purchase preference is 20%.

In respect of the above eligibility criteria the Bidder is required to furnish the following information online:

- i). Confirmation in the form of Yes/No regarding possessing of required document indicating percentage of local content as enlisted in NIT.

Note:-

(i) If the estimated value of Procurement is less than Rs. 10 crores, all the Bidders at the time of bidding shall submit self-certification indicating the percentage of local content in the offered items in Undertaking format at Annexure-III. They shall also give details of the location(s) at which the local value addition is made, if applicable.

(ii) If the estimated value of procurement is more than Rs. 10 crores, all the Bidders shall submit along with its bid a certificate (with UDIN) from the statutory auditor or cost auditor of the company (in case of companies) or from a practicing cost accountant or practicing chartered account (in respect of suppliers other than companies) giving the percentage of local content (with Annexure III).

Scanned copy of documents to be uploaded by bidder(s) in support of information / declaration furnished online by the bidder against Eligibility Criteria as Confirmatory Document.

In terms of the above said policy, purchase preference shall be given to local suppliers in the following manner:

- I. In the procurement of works which are divisible in nature, the following procedure shall be followed: -
- i) Among all qualified bids, the lowest bid will be termed as L-1. If L-1 is from a Class-I local supplier, the contract for full quantity will be awarded to L-1 at L-1 price by the Purchaser.
- ii) If L-1 is not a Class-I local supplier, 50% of the order quantity shall be awarded to L-1. Thereafter, the lowest Bidder among the Class-I local suppliers will be invited to match the L-1 price for the remaining 50% quantity subject to Class-I local supplier's quoted price falling within the margin of purchase preference, and the contract for that quantity shall be awarded to such local supplier subject to his matching the L-1 price. In case such lowest eligible Class-I supplier fails to match the L-1 price or accept less than the offer quantity, the next higher Class-I local supplier within the margin of purchase preference shall be invited to match the L-1 price for remaining quantity and so on, and contract shall be awarded accordingly. In case some quantity is still left uncovered on Class-I local supplier, then such balance quantity may also be ordered on L-1 Bidder.

- II. In the procurement of works which are not divisible, and in procurement of services where the bid is evaluated on price alone, the following procedure shall be followed: -
- i) Among all qualified bids, the lowest bid will be termed as L-1. If L-1 is from a Class-I local supplier, the contract will be awarded to L-1.
 - ii) If L-1 is not from a Class-I local supplier, the lowest Bidder among the Class-I local suppliers, will be invited to match the L-1 price subject to Class-I local supplier's quoted price falling within the margin of purchase preference, and the contract shall be awarded to such Class-I local supplier subject to matching the L-1 price.
 - iii) In case such lowest eligible Class-I local supplier fails to match the L-1 price, the Class-I local supplier with the next higher bid within the margin of purchase preference shall be invited to match the L-1 price and so on and contract shall be awarded accordingly. In case none of the Class-I local suppliers within the margin of purchase preference matches the L-1 price, then the contract may be awarded to the L-1 Bidder.

III. Applicability in tenders where contract is to be awarded to multiple bidders

In tenders where contract is awarded to multiple bidders subject to matching of L1 rates or otherwise, the 'Class-I local supplier' shall get purchase preference over 'Class-II local supplier' as well as 'Non-local supplier', as per following procedure:

- a) In case there is sufficient local capacity and competition for the item to be procured, as notified by the nodal Ministry, only Class I local suppliers shall be eligible to bid. As such, the multiple suppliers, who would be awarded the contract, should be all and only 'Class I Local suppliers'.
 - b) In other cases, 'Class II local suppliers' and 'Non local suppliers' may also participate in the bidding process along with 'Class I Local suppliers' as per provisions of the Order.
 - c) If 'Class I Local suppliers' qualify for award of contract for at least 50 (fifty) percent of the tendered quantity in any tender, the contract may be awarded to all the qualified bidders as per award criteria stipulated in the bid documents. However, in case 'Class I Local suppliers' do not qualify for award of contract for at least 50 (fifty) percent of the tendered quantity, purchase preference should be given to the 'Class I local supplier' over 'Class II local suppliers'/ 'Non local suppliers' provided that their quoted rate falls within margin of purchase preference of the L1 bidder considered for award of contract so as to ensure that the 'Class I Local suppliers' taken in totality are considered for award of contract for at least 50 (fifty) percent of the tendered quantity.
 - d) First purchase preference has to be given to the lowest quoting 'Class-I local supplier', whose quoted rates fall within margin of purchase preference, subject to its meeting the prescribed criteria for award of contract as also the constraint of maximum quantity that can be sourced from any single supplier. If the lowest quoting 'Class-I local supplier', does not qualify for purchase preference because of aforesaid constraints or does not accept the offered quantity, an opportunity may be given to next higher 'Class-I local supplier', falling within margin of purchase preference, and so on.
 - e) To avoid any ambiguity during bid evaluation process, the procuring entities may stipulate its own tender specific criteria for award of contract amongst different bidders including the procedure for purchase preference to 'Class-I local supplier' within the broad policy guidelines stipulated in sub-paras above.
- IV. **Requirement for specification in advance:** The minimum local content, the margin of purchase preference and the procedure for preference to Make in India shall be specified in the notice inviting tenders or other form of procurement solicitation and shall not be varied

during a particular procurement transaction.

V. Verification of local content:

- a) If the estimated value of Procurement is less than Rs. 10 crores, all the Bidders at the time of bidding shall submit self-certification indicating the percentage of local content in the offered items. They shall also give details of the location(s) at which the local value addition is made, if applicable.
- b) In cases of procurement for a value in excess of Rs. 10 crores, the 'Class-I local supplier'/ 'Class-II local supplier' shall be required to provide a certificate with UDIN from the statutory auditor or cost auditor of the company (in the case of companies) or from a practicing cost accountant or practicing chartered accountant (in respect of suppliers other than companies) giving the percentage of local content.
- c) Decisions on complaints relating to implementation of this Order, 2020 (amended from time to time) shall be taken by TAA limited to the CMD of CIL/Subsidiaries to the procuring entity.
- d) CIL/Subsidiary may constitute committees with internal and external experts for independent verification of self-declarations and auditor's/ accountant's certificates on random basis and in the case of complaints.
- e) False declarations will be debarment of the bidder or its successors for a period up to two years as per Guidelines on debarment of firms from bidding along with such other action as may be permissible under law.
- f) A supplier who has been debarred by any procuring entity for violation of the Order shall not be eligible for preference under the Order for procurement by any other procuring entity for the duration of the debarment. The debarment for such other procuring entities shall take effect prospectively from the date on which it comes to the notice of other procurement entities, in the manner prescribed below.
- g) The Department of Expenditure shall issue suitable instructions for the effective and smooth operation of this process, so that:
 1. The fact and duration of debarment for violation of the Order by any procuring entity are promptly brought to the notice of the Member-Convenor of the Standing Committee and the Department of Expenditure through the concerned Ministry /Department or in some other manner;
 2. on a periodical basis such cases are consolidated and a centralized list or decentralized lists of such suppliers with the period of debarment is maintained and displayed on website(s);
 3. In respect of procuring entities other than the one which has carried out the debarment, the debarment takes effect prospectively from the date of uploading on the website(s) in the such a manner that ongoing procurements are not disrupted.

VI. Reciprocity Clause

1. When a Nodal Ministry/Department *identifies* that Indian suppliers of an item are not allowed to participate and/ or compete in procurement by any foreign government, due to restrictive tender conditions which have direct or indirect effect of barring Indian companies such as registration in the procuring country, execution of projects of specific value in the procuring country etc., it shall provide such details to all its procuring entities including CMDs/CEOs of PSEs/PSUs, State Governments and other

procurement agencies *under their administrative control and GeM for appropriate reciprocal action.*

2. *Entities of countries which have been identified by the nodal ministry/departments not allowing Indian companies to participate in their Government procurement for any item related to that nodal Ministry shall not be allowed to participate in Government procurement in India (including CIL and its Subsidiaries) for all items related to that nodal Ministry/ Department, except for the list of items published by the Ministry/ Department permitting their participation.*
3. The term 'entity' of a country shall have the same meaning as under the FDI Policy of DPIIT as amended from time to time.

VII. Manufacture under license/ technology collaboration agreements with phased indigenization

- a) While notifying the minimum local content, Nodal Ministries may make special provisions for exempting suppliers from meeting the stipulated local content if the product is being manufactured in India under a license from a foreign manufacturer who holds intellectual property rights and where there is a technology collaboration agreement / transfer of technology agreement for indigenous manufacture of a product developed abroad with clear phasing of increase in local content.
- b) In procurement of all goods, services or works in respect of which there is substantial quantity of public procurement and for which the nodal ministry has not notified that there is sufficient local capacity and local competition, the concerned nodal ministry shall notify an upper threshold value of procurement beyond which foreign companies shall enter into a joint venture with an Indian company to participate in the tender. CIL/Subsidiary while procuring such items beyond the notified threshold value, shall prescribe in their respective tenders that foreign companies may enter into a joint venture with an Indian company to participate in the tender. CIL/Subsidiary shall also make special provisions for exempting such joint ventures from meeting the stipulated minimum local content requirement, which shall be increased in a phased manner.

Scanned copy of documents to be uploaded by bidder(s) in support of information / declaration furnished online by the bidder against Eligibility Criteria as Confirmatory Document.

9. Submission of Bid:

a.(i). In order to submit the Bid, the bidders have to get themselves registered online on the e-Procurement portal of CIL (<https://coalindiatenders.nic.in>) with valid Digital Signature Certificate (DSC) issued from any agency authorized by Controller of Certifying Authority (CCA), Govt. of India and which can be traced up to the chain of trust to the Root Certificate of CCA. The online Registration of the Bidders on the portal will be free of cost and one time activity only. The registration should be in the name of bidder, whereas DSC holder may be either bidder himself or his duly authorized person. The bidder is one whose name will appear as bidder in the e-Procurement Portal.

(ii). The bidders have to accept unconditionally the online user portal agreement which contains the acceptance of all the Terms and Conditions of NIT including General and Special Terms & Conditions, Integrity Pact and other conditions, if any, along with on-line undertaking in support of the authenticity of the declarations regarding the facts, figures, infor-

mation and documents furnished by the Bidder on-line in order to become an eligible bidder. No conditional bid shall be allowed/accepted.

(iii). The bidders have to accept unconditionally in GTE (General Technical Evaluation) the Undertaking at **Annexure II** regarding Genuineness of the information furnished by him on-line & authenticity of the scanned copy of documents uploaded by him on-line in support of his eligibility criteria etc. and **Annexure I** (Letter of Bid). No recycling will be done for this document i.e. no further clarification will be sought from bidder.

Moreover, the following documents shall be considered from the Bidder's space/ My Document and recycling may be done for these documents i.e. further clarification may be sought from bidder if required-

S.No.	Document	Information to be furnished by Bidder on line in GTE	Scanned documents to be uploaded by Bidder in Bidder's space/ My Document
1	Valid Permanent Account Number (PAN) (Ref. Clause No.8(C) of NIT)	Confirmation in the form of Yes/NO for possessing the supporting documents	PAN card issued by Income Tax department, Govt. of India. In case of JV, PAN card for each Indian partner of JV and Verifiable Tax Residency Certificate of respective country for each foreign partner or JV itself.
2	Goods and Services Tax (Not Applicable for Exempted Services) (Ref. Clause No.8(D) of NIT and BOQ)	1. Confirmation in the form of Yes/No regarding possessing of required document as enlisted in NIT with respect to GST status of the Bidder 2. Status of the Bidder in the BOQ excel sheet being uploaded by the Bidder during bid submission.	The following documents depending upon the status w.r.to GST as declared by Bidder in the BOQ sheet: a) Status: <u>GST Registered Bidder under regular scheme</u> Document: GST Registration Certificate (i.e. GST identification Number) issued by appropriate authority of India. b) Status: <u>GST Registered Bidder under composition scheme</u> Document: GST Registration Certificate (i.e. GST identification Number) issued by appropriate authority of India. c) Status: GST unregistered bidder:

			<p>Document: A Certificate having UDIN from a practicing Chartered Accountant having membership number with Institute of Chartered Accountants of India certifying that the bidder is GST unregistered bidder in compliance with the relevant GST rules of India.</p> <p>[In case of JV, Bidder should submit scanned copy of GST status of Lead Partner only or GST Certificate of JV itself]</p> <p>Note:</p> <p><i>i) If turnover of bidder exceeds exemption/threshold limit, the bidder must have GST registration as per GST Act and rules</i></p>
3	Legal Status of the bidder	Confirmation in the form of Yes/NO for possessing the supporting documents	<p><u>Document(s) covered under any one of the following sub-head(s):</u></p> <ol style="list-style-type: none"> 1. Affidavit or any other document to prove proprietorship/Individual status of the bidder. 2. Partnership deed containing name of partners. 3. Memorandum & Article of Association with certificate of incorporation containing name of bidder. 4. The following documents in respect of Legal Status of a JV Bidder shall be uploaded in Bidder's Space by the JV Bidder: <ol style="list-style-type: none"> i. Scanned copy of JV Agreement containing name of partners and lead partner, Power of Attorney to the lead partner and share of each partner as per Annexure-XV. ii. Power of attorney of the respective partners from the Board of

			<p>Directors of the concerned Company, or from the partners of the entity, or from the proprietor, authorizing the signatory of JV agreement on behalf of them.</p> <p>iii. The document(s) (any of them as applicable) regarding legal status of all the individual partners of JV mentioned below:</p> <p>a) Affidavit or any other document to prove Proprietorship/Individual status of the Bidder.</p> <p style="text-align: center;">OR</p> <p>b) Partnership deed containing name of partners.</p> <p style="text-align: center;">OR</p> <p>Memorandum & Article of Association with certificate of incorporation containing name of Bidder.</p>
<p>Note: Only one file in .pdf format can be uploaded against each eligibility criteria. Any additional/ other relevant documents to support the information/declaration furnished by Bidder online against eligibility criteria may also be attached by the Bidder in the same file to be uploaded against respective eligibility criteria.</p>			

b. Confirmatory Documents: All the confirmatory documents as enlisted in the NIT in support of online information submitted by the bidder are to be uploaded in Cover-I by the bidder while submitting his/her/their bid.

S.No.	Eligibility Criteria	Scanned copy of documents, to be uploaded by Bidders in support of information/ declaration furnished online by the Bidder against Eligibility Criteria (Confirmatory Document)
1	2	3
1	Work Experience (Ref. Clause No.8(A) of NIT)	<p>Satisfactory Work Completion Certificate issued / Passed copy of final bill duly accepted by EIC (Engineer Incharge) against the experience of similar work containing all the information as sought on-line.</p> <p>Work order, BOQ, TDS may be sought during clarification or along with deficient documents as per clause 13(B), if</p>

		<p>felt necessary by the Tender Committee.</p> <p><i>(In case of JV, Satisfactory Work Completion Certificate against individual partner(s) including Lead Partner of JV as applicable as per details mentioned in clause No. 8.</i></p>
2	<p>Financial Turnover (Ref. Clause No.8(B) of NIT)</p> <p><u>(Financial Turnover criteria is not applicable for tenders with ECV below 50 lakh)</u></p>	<p>Financial Turnover certificate having a Unique Document Identification Number (UDIN)with Institute of Chartered Accountants of India for last 3 (three) financial years issued by a Practicing Chartered Accountant having a membership number with Institute of Chartered Accountants of India.</p> <p><i>(In case of JV, Turnover certificate for each individual partner of JV)</i></p>
3	Valid Digital Signature Certificate	<p>If the Bidder himself is the DSC holder bidding on-line then no document is required.</p> <p>However, if the DSC holder is bidding online on behalf of the Bidder then the Power of Attorney or any sort of legally acceptable document for the authority to bid on behalf of the Bidder.</p>
4	<p>VALID ELECTRICAL LICENSE (For Electrical works only)</p>	<p>Valid Electrical Contractor's License issued by Electrical Licensing Board/Authority of any Indian State/UT, in accordance with IE Rule-45.</p> <p><i>(In case the Bidder is a Joint Venture, at least one partner of JV should possess the valid Electrical Contractor's License issued by Electrical Licensing Board/Authority of any Indian state, in accordance with IE Rule-45.)</i></p>
5	Workshop & Testing Facilities etc., (if asked in case of repair at bidder's work premises)	Self-certified copy of List of Plant & Machinery etc. installed in bidder's workshop/factory duly originally authenticated by their bankers/Chartered Accountant or issued by any Government Agency.
6	Undertaking by bidder on his/her/their Letter Head as per Annexure-III	Undertaking regarding relatives as employees of company, Local supplier status of the Bidder as per clause 8E of NIT, declaration w.r.t Make in India order dated 16.09.2020, Code of Integrity for Public Procurement (CIPP) and compliance w.r.t procurement from bidder of a country which shares a border with India etc.
<p>Note: Only one file in .pdf format can be uploaded against each eligibility criteria. Any additional/ other relevant documents to support the information/declaration furnished by Bidder online against eligibility criteria may also be attached by the Bidder in the same file to be uploaded against respective eligibility criteria.</p>		

c. Letter of Bid (LoB): The format of Letter of Bid is given at Annexure I of Tender document. This will be the covering letter of the bidder for his submitted bid. The bidders have to accept uncon-

ditionally the Letter of Bid in GTE (General Technical Evaluation) at the time of bid submission. This online acceptance during bidding through GTE shall be construed as submission of LOB by bidder

d. Price bid: The Price bid containing the Bill of Quantity will be in Excel format and will be downloaded by the bidder and bidder will quote the rates for all items on this Excel file. Prior to quoting the rates in the BOQ file, the bidder will select the appropriate status from the following drop down list given in the BOQ:-

- I. Status: GST Registered Bidder under regular scheme
- II. Status: GST Registered Bidder under composition scheme
- III. Status: GST unregistered bidder

The rates quoted by the bidder will be excluding GST and GST component (to be paid by CIL / Subsidiary and/or the bidder) will appear as a separate entity. The component of GST will be taken by the system based on the status of bidder selected by the bidder during bid submission and with the pre-defined business logic given in the BOQ file by the department. This file will be digitally signed and uploaded by the bidder after ascertaining the correctness of facts and figures.

Thereafter, the bidder will upload the same Excel file during bid submission in cover-II. The Price-bid (excluding GST) will be in Item Rate or Percentage Rate or Mixed Rate[combination of Item Rate and Percentage Rate] BOQ format and the bidder will have to quote for all the tendered items. The Price Bid of the tenderers will have no condition. The price bid which is incomplete and not submitted as per instruction given in this document is liable for rejection.

System for decision of L1 bidder

The L1 bidder will be decided based on Overall Quoted Value (i.e. cost to the Company). The system for decision of L1 bidder will be as per following 02(two) cases:-

Case – 1: Supply for which INPUT TAX CREDIT (ITC) is not available to the Company.

For calculation of Overall Bid Value, the GST [CGST, SGST/UTGST, IGST and GST (compensation to state tax)] to be paid by the bidder **or** by CIL/ Subsidiary taken by the system will be added to decide the L1 i.e the ranking of the Bidders will be decided based on rates quoted by the bidders plus GST. This value of the bidder will be “the Cost to Company”.

Then share of GST to be deposited by CIL/ Subsidiary, if any will be deducted from overall bid value to arrive at the Contract value. The Price-bids of the tenderers shall have no condition. The Price Bid which is incomplete and not submitted as per instruction given above is liable for rejection.

Case – 2: Supply for which INPUT TAX CREDIT (ITC) is available to the Company.

For calculation of Overall Bid Value, the GST [CGST, SGST/UTGST, IGST and GST (compensation to state tax)] to be paid by the Bidder **or** by CIL/ Subsidiary taken by the system will be ignored to decide the L1 i.e the ranking of the Bidders will be decided based on rates quoted by the bidders excluding GST. This value of the bidder will be “the cost to Company”.

Then share of GST to be paid by bidder shall be added with overall bid value to arrive at the Contract value. The Price-bids of the tenderers shall have no condition. The Price Bid which is incomplete and not submitted as per instruction given above is liable for rejection.

Note: The bidder should select their GST category as per clause no. 8.D of NIT.

10. Bid Submission:

All bids are to be submitted on-line on the website <https://coalindiatenders.nic.in>. No bid shall be accepted off-line unless otherwise specified.

11. System Requirement:

It is the bidder's responsibility to comply with the system requirement i.e. hardware, software and internet connectivity at bidder's premises to access the e-tender website. Under any circumstances, CIL/ Subsidiary shall not be liable to the bidders for any direct/indirect loss or damages incurred by them arising out of incorrect use of the e-tender system or internet connectivity failures.

12. Opening of Technical Bid:

12.1 The Technical bid (Cover-I) will be opened one day after the Bid submission end date or next working day whichever is later. Technical bid (Cover-I) will be decrypted and opened online by the "Bid Openers" with their Digital Signature Certificates after the prescheduled date & time of Tender Opening.

12.2 The e-Procurement System will evaluate the Technical bids automatically on the basis of relevant data provided by bidder through a form in an objective and structured manner while submitting bid. If the parameter given by bidder in objective and structured manner does not confirm to required eligibility criteria as specified in the tender document then the bid will be auto rejected.

12.3 All the documents uploaded by bidder(s) including EMD exemption documents (if any) and the Evaluation sheets generated by the system online shall be downloaded after opening of Technical bid (Cover-I). After decryption and opening of Technical bid (Cover-I) the "technical bid opening summary" will be uploaded on the same day.

13. Technical Evaluation of Tender:

- a) After opening of Technical bid, the documents submitted by bidder(s) as enlisted in the NIT will be downloaded by the Evaluator and shall be put up to the Tender Committee. The Tender Committee will examine the uploaded documents against information/declarations furnished by the bidder(s) online. If it confirms to all of the information/ declarations furnished by the bidder online and does not change the eligibility status of the bidder then the bidder will be considered eligible for opening of price bid.
- b) In case the Tender Committee finds that there is some deficiency in uploaded documents corresponding to the information furnished online or in case corresponding document have not been uploaded by bidder(s) then the same will be specified online by Evaluator clearly indicating the omissions/shortcomings in the uploaded documents and indicating start date and end date allowing 7 days (7 x 24 hours) time for online re-submission by bidder(s). The

bidder(s) will get this information on their personalized dashboard under “Upload confirmatory document” link. Additionally, information shall also be sent by system generated email and SMS, but it will be the bidder’s responsibility to check the updated status/information on their personalized dash board regularly after opening of bid. No separate communication will be required in this regard. Non-receipt of e- mail and SMS will not be accepted as a reason of non-submission of documents within prescribed time. The bidder(s) will upload the scanned copy of all those specified documents in support of the information/ declarations furnished by them online within the specified period of 7 days. No further clarification shall be sought from Bidder.

Note: The shortfall information/ documents should be sought only in case of historical documents which pre-existed at the time of the tender opening and which have not undergone change since then. These should be called only on basis of the recommendations of the TC. So far as the submission of documents is concerned with regard to qualification criteria, after submission of the tender, only related shortfall documents should be asked for and considered

Not to be the part of tender document: For example, if the bidder has submitted a contract without its completion/ performance certificate, the certificate can be asked for and considered. However, no new contract should be asked for so as to qualify the bidder.

- c) It is responsibility of Bidders to upload legible/clearly readable scanned copy of all the required documents.
- d) The tender will be evaluated on the basis of documents uploaded by Bidder(s) online. The Bidder(s) is/are not required to submit hard copy of any document through offline mode. Any document submitted offline will not be given any cognizance in the evaluation of tender.
- e) In case the Bidder(s) submit(s) requisite documents online as per NIT, then the Bidder(s) will be considered eligible for opening of Price Bid.
- f) Seeking clarification shall be restricted to confirmation of submitted document/online information only and it should be only for one time for a period of upto 7 days. The clarification shall be taken in online mode in the e-Procurement portal of CIL only.
- g) In case Bidder(s) fails to confirm the online submitted information(s)/ declaration(s) by the submitted documents as (b) above, their/his bid shall be rejected; however, if the confirmatory documents do not change eligibility status of the Bidder in connection his submitted online information(s)/declaration(s), then his/their bid will be accepted for opening of Price Bid.
- h) After Technical evaluation of tender, “Technical Evaluation Summary” will be uploaded by the Evaluator and price bid shall be opened on preschedule date and time mentioned in the NIT online in the e-Procurement portal of CIL. However, in case there is any extension of date and time of price bid opening, it shall be notified online and price bid shall be opened online on e-Procurement portal of CIL at rescheduled date and time.
- i) In case none of the Bidder(s) complies the technical eligibility criteria as per NIT, then Bidder(s) will be rejected online and re-tender (if required) will be done (with the same or different quantity, as per the instant requirement).

- j) If L1 bidder backs out (i.e. Techno commercially established L1 bidder), the EMD will be forfeited and the bidder will be debarred for minimum one (1) year from participating in tenders in CIL/ Subsidiary.

Note: In case If the defaulter L1 bidder is a Joint Venture (JV) firm, penal action against the JV will also be applicable to all the partners of JV.

- k) **Preference to Make in India (as applicable) vide Order No. P-45021/2/2017-PP (BE-II) dated 16.09.2020, issued by Govt. of India as amended from time to time shall be applicable.**

In terms of the above said policy, purchase preference shall be given to local suppliers in the following manner :

I. In the procurement of works which are divisible in nature, the following procedure shall be followed: -

i) Among all qualified bids, the lowest bid will be termed as L-1. If L-1 is from a Class-I local supplier, the contract for full quantity will be awarded to L-1 at L-1 price by the Purchaser.

ii) If L-1 is not a Class-I local supplier, 50% of the order quantity shall be awarded to L-1. Thereafter, the lowest Bidder among the Class-I local suppliers will be invited to match the L-1 price for the remaining 50% quantity subject to Class-I local supplier's quoted price falling within the margin of purchase preference, and the contract for that quantity shall be awarded to such local supplier subject to his matching the L-1 price. In case such lowest eligible Class-I supplier fails to match the L-1 price or accept less than the offer quantity, the next higher Class-I local supplier within the margin of purchase preference shall be invited to match the L-1 price for remaining quantity and so on, and contract shall be awarded accordingly. In case some quantity is still left uncovered on Class-I local supplier, then such balance quantity may also be ordered on L-1 Bidder.

II. In the procurement of works which are not divisible, and in procurement of services where the bid is evaluated on price alone, the following procedure shall be followed: -

i) Among all qualified bids, the lowest bid will be termed as L-1. If L-1 is from a Class-I local supplier, the contract will be awarded to L-1.

ii) If L-1 is not from a Class-I local supplier, the lowest Bidder among the Class-I local suppliers, will be invited to match the L-1 price subject to Class-I local supplier's quoted price falling within the margin of purchase preference, and the contract shall be awarded to such Class-I local supplier subject to matching the L-1 price.

iii) In case such lowest eligible Class-I local supplier fails to match the L-1 price, the Class-I local supplier with the next higher bid within the margin of purchase preference shall be invited to match the L-1 price and so on and contract shall be awarded accordingly. In case none of the Class-I local suppliers within the margin of purchase preference matches the L-1 price, then the contract may be awarded to the L-1 Bidder.

Note: The confirmation from the Bidder regarding matching of L1 price may be taken in confirmatory document link of e-Procurement portal by recycling 'Any other document' link.

Verification of local content:

- I. If the estimated value of Procurement is less than Rs. 10 crores, all the Bidders at the time of bidding shall submit either self-certification indicating the percentage of local content in the offered items in Undertaking as per format at **Annexure-III**. They shall also give details of the location(s) at which the local value addition is made, if applicable.
- II. If the estimated value of procurement is more than Rs. 10 crores, all the Bidders shall submit along with its bid a certificate with UDIN from the statutory auditor or cost auditor of the company (in case of companies) or from a practicing cost accountant or practicing chartered account (in respect of suppliers other than companies) giving the percentage of local content.
- III. CIL/ Subsidiary may constitute committees with internal and external experts for independent verification of auditor's / accountant's certificates on random basis and in the case of complaints.
- IV. False declarations will attract Guidelines on Debarment of firms from Bidding for a period up to two year and with process in line with clause 17 of GTC.
- V. A local supplier who has been debarred by any procuring entity for violation of above order shall not be eligible for preference under this Order for procurement by any other procuring entity for the duration of debarment. The debarment for such other procuring entities shall take effect prospectively from the date on which it comes to the notice of other procurement entities.

14. Auto Extension of Critical Date

If number of bids received online is found to be less than 03(three) on end date of bid submission then the following critical dates of the Tender will be automatically extended for a period of four days ending at 17.00 hrs::

- Last date of submission of Bid.
- Last date of receipt of EMD.
- Date of Opening of Tender.

If any of the above extended Dates falls on Holiday i.e. a non-working day as defined in the e-Procurement Portal then the same is to be rescheduled to the next working day.

This extension will be also applicable in case of receipt of zero bid.

Notes:

1. The validity period of tender should be decided based on the final end date of submission of bids.
2. The auto extension shall work on the basis of number of bids received only. It may so happen that any of these bids may be eventually rejected during Tender Opening, Technical evaluation or further process of evaluation resulting the total number of valid bids becoming less than 03(three).
3. After extension, the tender shall be opened irrespective of available number of bids on the extended date of opening of tender

15. One Bid per Bidder:

15.1 Each Bidder shall submit only one Bid, either individually, or as a proprietor, or as a partner in a partnership firm or as a partner in a joint venture or as a Company registered under Companies Act. A Bidder who submits or participates in more than one Bid (other than as a sub-contractor or in cases of alternatives that have been permitted or requested) will cause all the proposals with the Bidder's participation to be disqualified.

16. Refund of EMD:

- a) If EMD is paid by the bidder in online mode (Direct Debit/NEFT/RTGS) then the EMD of rejected bidders will be refunded at any stage directly to the account from where it had been received (except the cases where EMD is to be forfeited).
- b) No claim from the bidders will be entertained for non-receipt of the refund in any account other than the one from where the money is received.
- c) If the refund of EMD is not received by the bidder in the account from which the EMD has been made due to any technical reason then it will be paid through conventional system of e-payment. For this purpose, if required, Tender Inviting Authority will obtain the Mandate Form from the Bidder.
- d) In case the tender is cancelled then EMD of all the participating bidders will be refunded unless it is forfeited by the department.
- e) If the bidder withdraws his/her bid online (i.e. before the end date of submission of tender) then his/her EMD will be refunded automatically after the opening of tender.

At the option of bidder, the EMD of successful bidder (on Award of Contract) will be retained by CIL/ Subsidiary and will be adjusted to Performance Security Deposit.

17. Site Visit:

17.1 The bidder, at the Bidder's own responsibilities, cost and risk, is encouraged to visit and examine the Site of Works and its surrounding, approach road, soil condition, investigation report, existing works, if any, connected to the tendered work, drawings connected to the work, if / as available and obtain all information that may be necessary for preparing the Bid and entering into a contract for execution of the works. The cost of visiting the Site shall be at the Bidder's own expense.

17.2 It shall be deemed that the Bidder has visited the Site/Area and got fully acquainted with the working conditions and other prevalent conditions and fluctuations thereto whether he/she/they actually visits the Site /Area or not and has taken all the factors into account while quoting his/her/their rates.

17.3 The Bidder is expected, before quoting his rate, to go through the requirement of materials/workmanship, specification, requirements and conditions of contract.

17.4 The Bidder, in preparing the bid, shall rely on the site investigation report referred to in the bid document (if available), supplemented by any information available to the Bidder.

18. Taxes and Duties:

All duties, taxes (excluding Goods and Services Tax (GST) & GST Compensation Cess (if applicable) only) and other levies, royalty, building and construction workers cess (as applicable in States) payable by the bidder/Contractor under the Contract, or for any other cause as applicable on the last date of submission of Bid, shall be included in the rates, prices and the total Bid Price submitted by the Bidder. Applicable GST, if any, either payable by bidder or by company under reverse charge mechanism shall be computed by system in BOQ sheet as per predefined logic.

All investments, operating expenses, incidentals, overheads, leads, lifts, carriages, tools and plants etc. as may be attendant upon execution and completion of works shall also be included in the rates, prices and total Bid price submitted by the bidder.

However, such duties, taxes, levies etc. which is notified after the last date of submission of Bid and/or any increase over the rate existing on the last date of submission of Bid shall be reimbursed by the company on production of documentary evidence in support of payment actually made to the concerned authorities.

Similarly, if there is any decrease in such duties, taxes and levies the same shall become recoverable from the contractor. The details of such duties, taxes and other levies along with rates shall be declared by the bidder.

The item wise rate quoted by bidder shall be inclusive of all taxes, duties & levies but excluding GST & GST Compensation Cess, if applicable. The payment of GST and GST Compensation Cess by service availer (i.e. CIL/Subsidiary) to bidder/contractor (if GST payable by bidder/contractor) would be made only on the latter submitting a Bill/invoice in accordance with the provision of relevant GST Act and the rules made there under and after online filing of valid return on GST portal. Payment of GST & GST Compensation Cess is responsibility of the service provider/contractor.

Further, any GST credit note required to be issued by the bidder / contractor under the GST provisions should be issued within the time limit prescribed under the GST law.

However, in case bidder/contractor is GST unregistered bidder/dealer or GST registered under composition scheme in compliance with GST rules, the bidder/dealer shall not charge any GST and/or GST Compensation Cess on the bill/invoice. In case of unregistered dealer/bidder, GST, if applicable will be deposited by CIL/Subsidiary directly to concerned authorities in terms with GST provisions.

Input tax credit is to be availed by CIL/Subsidiary as per rule.

If CIL/Subsidiary fails to claim Input Tax Credit(ITC) on eligible Inputs, input services and Capital Goods or the ITC claimed is disallowed due to failure on the part of supplier/vendor of goods and services in incorporating the tax invoice issued to CIL/Subsidiary in its relevant returns under GST, payment of CGST & SGST or IGST, GST (Compensation to State) Cess shown in tax invoice to the tax authorities, issue of proper tax invoice or any other reason whatsoever, the applicable taxes & cess paid based on such Tax invoice shall be recovered from the current bills or any other dues of the supplier/vendor along with interest and penalty, if any.

The rates and prices quoted by the Bidder shall be fixed for the duration of the contract and shall not be subject to variations on any account except to the extent variations allowed as per the conditions of the contract of the bidding document.

The company reserves the right to deduct/ withhold any amount towards taxes, levies, etc. and to deal with such amount in terms of the provisions of the Statute or in terms of the direction of any statutory authority and the company shall only provide with certificate towards such deduction and shall not be responsible for any reason whatsoever.

In case of collection of minor minerals in area (both virgin and non-virgin), acquired by the Company under the Coal Act, the contractor will have to produce a royalty clearance certificate from the District Authorities before full and final payment.

Note:

During the execution of the contract if the GST status of the bidder changes, then the payment of GST, if any, to the contractor will be made as per the GST status declared by the bidder during tender stage based on which cost to company has been ascertained or at actuals, whichever is lower.

19. Cost of Bidding:

The bidder shall bear all costs associated with the preparation and submission of his bid and the Employer will in no case be responsible or liable for those costs.

20. Technical Specifications:

The tenderer shall closely study all specifications in detail, which govern the rates for which he is tendering.

21. Currencies of Bid and Payment:

The unit rates and prices shall be quoted by the Bidder entirely in Indian Rupees only.

22. Handing Over of Site:

On completion of the work all rubbish, debris, brick bats etc. shall be removed by the contractor(s) at his/their own expense and the site cleaned and handed over to the company and he/they shall intimate officially of having completed the work as per contract.

23. Deployment of Manpower and Machineries:

The tenderer(s) will deploy sufficient number and size of equipments/machineries/vehicles and the technical/ supervisory personnel required for execution of the work.

24. Change in Constitution of the Contracting Agency:

Prior approval in writing of the company shall be obtained before any change is made in the constitution of the contracting agency, otherwise it will be treated as a breach of Contract.

25. Canvassing in Tender:

Canvassing in connection with the tenders in any shape or form is strictly prohibited and tenders submitted by such tenderers who resort to canvassing shall be liable for rejection.

26. Letter of Acceptance (LOA)/Work Order/Agreement:

The Bidder, whose Bid has been accepted, will be notified /communicated by the Employer electronically online on the e-procurement portal of CIL prior to expiration of the Bid validity period. The L-1 bidder will get the information regarding award of work on their personalised dash-board on-line. On receipt of Letter of Acceptance (LOA)/Work Order of the ten-

der issued by the Company, the successful tenderer shall execute contract agreement in the company's prescribed form for the due fulfilment of the contract. Failure to enter into the required contract within the specified period in the work order shall entail cancellation of LOA/work order and forfeiture of the Earnest Money. In addition, the department may debar the bidder from participating in future bids for at least 12 months as per Guidelines on Debarment of firms from Bidding.

27. Bid Validity:

The validity period of the tenders shall be **120(One Hundred Twenty)** days from the end date of bid submission. The validity period of tender shall be decided based on the final end date of submission of bids.

In exceptional circumstances, prior to expiry of the original time limit, the Employer may request the bidders (all the responsive tenderers) to extend the period of validity for a specified additional period. The employer's request and the bidder's responses shall be made in writing. A bidder may refuse the request without forfeiting his bid security. A bidder agreeing to the request will not be required or permitted to modify his bid.

The tenderer shall not, during the said period or within the period extended by mutual consent, revoke or cancel his tender or alter the tender or any terms/conditions thereof without consent in writing of the company. In case the tenderer violates to abide by this, the Company will be entitled to take action as per clause No.28 (Modification and Withdrawal of Bid) of NIT.

28. Modification and Withdrawal of Bid:

Modification of the submitted bid shall be allowed on-line only before the deadline of submission of tender and the bidder may modify and resubmit the bid on-line as many times as he may wish. Bidders may withdraw their bids online within the end date of bid submission and their EMD will be refunded. However, if the bidder once withdraws his bid, he will not be able to resubmit the bid in that particular tender. For withdrawal of bid after the end date of bid submission, the bidder will have to make a request in writing to the Tender Inviting Authority. Withdrawal of bid may be allowed till issue of work order/LOA with the following provision of penal action:

a. If the request of withdrawal is received before online notification for opening of price bid, the EMD will be forfeited and bidder will be debarred for minimum 1 (one) year from participating in tenders in CIL/Subsidiary. The Price-bid of remaining bidders will be opened and the tender process shall go on.

b. If the request of withdrawal is received after online notification for opening of price bid, the EMD will be forfeited and the bidder will be debarred for minimum 1 (one) year from participating in tenders in CIL/Subsidiary. The Price-bid of all eligible bidders including this bidder will be opened and action will follow as under:

- i.** If the bidder withdrawing his bid is other than L 1, the tender process shall go on.
- ii.** If the bidder withdrawing his bid is L-1, then re-tender will be done.

Note:

i). In case of above, a letter will be issued to the bidder by Tender Inviting Authority with the approval of Tender Accepting Authority (in case Board is Tender Accepting Authority then with the approval of CMD), stating that the EMD of bidder is forfeited, and this bidder is debarred for.....year from participating in tenders in CIL/Subsidiary. This letter will be circulated to all Areas and CIL/Subsidiary HQ and the updated list will be maintained by all Tender Inviting Authority/Evaluators.

ii). Penal action against clause (a) & (b) above will be enforced from the date of issue of such order. The standard operating procedure to handle withdrawal of bid after end date of submission shall be as per Clause no 29 (Standard Operating Procedure for Withdrawal of Bid) of NIT.

29. Standard Operating Procedure for Withdrawal of Bid:

I. The Mode of withdrawal: -

A. Online Withdrawal of Bids:

- a. The system of online withdrawal is available on the portal up to end date of bid submission, where any bidder can withdraw his/her bid which will attract no penal action from department side.
- b. The system of online withdrawal beyond end date of bid submission and till award of contract is also available but not fully functional and under development stage. Once it is developed and implemented only online withdrawal shall be considered except for some exceptional cases as mentioned in clause below.

B. Offline Withdrawal of Bids :

- a. A partner of bidder (in case of JV and partnership firms) whose DSC is registered on the e-Procurement portal can access the portal for online withdrawal but when there is a split in the business relationship, the partners whose DSC is not registered on the portal do not have the option of online withdrawal of bid. Hence such partners may opt to use offline method of withdrawal of his/her offer (or express his disassociation from the bidder organization).
- b. Till a fully functional system of online withdrawal of bid (beyond end date of bid submission and till award of contract) is not developed and implemented, offline withdrawal shall also be considered.

II . Acceptance of withdrawal by Tender Committee:

- A. Every case of withdrawal under Clause I-(A) (b) and Clause I-(B) shall be put up to Tender Committee for deliberation and further course of action.
- B. The Tender Committee shall apply its due diligence to decide:
 - a. Whether the request for withdrawal of offer has been received from right source and authentic. For this purpose a letter is to be sent by registered post/speed post to the bidder on the address as given by him in the enrollment page of e-Procurement portal, allowing 10 days' time to confirm the withdrawal. If the bidder does not confirm the withdrawal within the stipulated period then it should be construed that there is no withdrawal of bid. In case the withdrawal/disassociation from the firm (Joint Venture or Partnership firm) has been submitted by any other partner then also the confirmation has to be sought from the bidder and if bidder wants to deny the withdrawal/disassociation from the JV or the partnership firm then the bidder shall be required to furnish a legally acceptable document signed by all the partners of the firm to substantiate his claim.
 - b. Whether the withdrawal is due to the reason other than to support any mala fide intention of any participating bidder such as participating or supporting a cartel formation etc.

- c. If the mala fide intentions in the withdrawal are apprehended then the tender should be cancelled apart from other penal action as per e-Procurement Manual for works and services of CIL and other guidelines/manuals of CIL.
- d. If no mala fide intentions in the withdrawal are apprehended then the penal action in line with the prescriptions of the e-Procurement Manual for works and services of CIL will be applicable.
- e. The Tender Committee may also obtain the opinion of legal department in order to ascertain the legal course of action in case of Clause II-(B)(b) and II-(B)(c) above.

30. Postponement of scheduled date(s):

The Company reserves the right to postpone the date of receipt and opening of tenders or to cancel the tenders without assigning any reason whatsoever.

31. Public Enterprises preference:

The Company reserves its right to allow Public Enterprises purchase preference facility as admissible under prevailing policy.

32. Contract Agreement Document(s):

This Tender Notice shall be deemed to be part of the Contract Agreement. The “General Terms & Conditions”, Additional Terms & Conditions, Special Terms & Conditions (if any), Technical Specifications, drawings (if any) and any other document uploaded on portal as NIT document forms an integral part of this NIT and shall also form a part of the contract agreement as per clause 2 of General Terms and Conditions.

33. Sub-letting of Work:

No subletting of work as a whole by the contractor is permissible. Subletting of work in piece rated jobs is permissible with the prior approval of the department. The total value of subcontracted work should not exceed 25% of the contract price specified in the contract. Procurement of material, hiring of equipment or engagement of labour will not mean sub-contracting.

If a contractor submits his bid qualifies but does not get the contract because of his being not the lowest, he will be prohibited from working as a sub-contractor for the contractor who is executing the contract.

The Contract Agreement will specify major items of supply or services for which the contractor proposes to engage sub-contractor/sub-vendor. The contractor may from time to time propose any addition or deletion from any such list and will submit proposals in this regard to the Engineer-in -Charge/Designated Officer-in-charge for approval well in advance so as not to impede the progress of work. Such approval of the Engineer-in-Charge/Designated Officer-in-Charge will not relieve the contractor from any of his obligations, duties and responsibilities under the contract.

34. Prohibition of Child Labour engagement:

The contractor/contractual Agencies must not engage any Child Labour during the course of execution of the contract work within the meaning and scope of the Child Labour Prohibition & Regulation Act-1986 and its relevant Act and Rules amended from time to time by the Govt. of India.

35. Implementation of CMPF/EPF:

The tenderer shall have to ensure implementation of CMPF/EPF, if applicable, in respect of the workers deployed by him as detailed in the tender document.

36. Splitting up of the work:

The Company does not bind itself to accept the lowest tender and reserves the right to reject any or all the tenders without assigning any reasons whatsoever and to split up the work between two or more tenderer(s) or accept the tender in part and not in its entirety.

37. Settlement of Disputes:

Matters relating to any dispute or difference arising out of this tender and subsequent contract Awarded based on this tender, shall be dealt as per Clause No. 13- title- 'Settlement of Disputes' of the 'General Terms and Conditions' of 'Conditions of Contract' of the tender document.

38. Restrictions on Procurement from a bidder of a country which shares a land border with India and on sub-contracting to contractors from such countries:

The guidelines as per order no.F.No.6/18/2019-PPD dt 23/7/2020 of Ministry of Finance, Gol as amended from time to time shall be applicable.

- I. Any bidder from a country which shares a land border with India will be eligible to bid in this tender only if the bidder is registered with the Competent Authority.
- II. "Bidder" (including the term 'tenderer', 'consultant' or 'service provider' in certain context) means any person or firm or company, including any member of a Joint venture (that is an association of several persons or firms or companies), every artificial juridical person not falling in any of the descriptions of bidders stated herein before, including any agency, branch or office controlled by such person, participating in a procurement process.
- III. "Bidder from a country which shares a land border with India" for the purpose of order F.No. 6/18/2019-PPD dated 23.07.2020 means :-
 - a. An entity incorporated, established or registered in such a country; **or**
 - b. A subsidiary of an entity incorporated, established or registered in such a country; **or**
 - c. An entity substantially controlled through entities incorporated, established or registered in such a country; **or**
 - d. An entity whose beneficial owner is situated in such a country; **or**
 - e. An Indian (or other) agent of such an entity; **or**
 - f. A natural person who is a citizen of such a country; **or**
 - g. A joint venture where any member of the joint venture falls under any of the above.
- IV. "The beneficial owner" for the purpose of (III) above will be as under:
 1. In case of a company or Limited Liability Partnership, the beneficial owner is the natural person(s), who, whether acting alone or together, or through one or more juridical person(s), has a controlling ownership interest or who exercises control through other means.

Explanation-

- a. "Controlling ownership interest" means ownership of, or entitlement to more than Twenty Five Percent of shares or capital or profits of the company;
- b. "Control" shall include the right to appoint the majority of the directors or to control the management or policy decisions, including by virtue of their

- shareholding or management rights or shareholders agreements or voting agreements;
2. In case of a partnership firm, the beneficial owner is the natural person(s) who, whether acting alone or together, or through one or more juridical person, has ownership of entitlement to more than fifteen percent of capital or profits of the partnership;
 3. In case of an unincorporated association or body of individuals, the beneficial owner is the natural person(s), who, whether acting alone or together, or through one or more juridical person, has ownership of or entitlement to more than fifteen percent of the property or capital or profits of such association or body of individuals.
 4. Where no natural person is identified under (1) or (2) or (3) above, the beneficial owner is the relevant natural person who holds the position of senior managing official.
 5. In case of a trust, the identification of beneficial owner(s) shall include identification of the author of the trust, the trustee, the beneficiaries with fifteen percent or more interest in the trust and any other natural person exercising ultimate effective control over the trust through a chain of control or ownership.
- V. An Agent is a person employed to do any act for another, or to represent another in dealings with third person.
- VI. The successful bidder shall not be allowed to sub-contract works to any contractor from a country which shares a land border with India unless such contractor is registered with the competent Authority.

Note:

1. (a) The intending bidders must submit a Certificate in the Undertaking at Annexure III in compliance to order no.F.No.6/18/2019-PPD dt 23/7/2020 and as amended from time to time of Ministry of Finance, Gol.

AND

(b) Valid registration from competent authority (if applicable). Registration should be valid at the time of submission of bid and at the time of acceptance of bids.
2. Guidelines issued by Gol regarding registration with Competent Authority and regarding exclusion from restriction may please be referred.

39. Code of Integrity for Public Procurement (CIPP)

The bidders/ contractors are required to abide the Code of Integrity for Public Procurement (CIPP) as given in the tender document at **Annexure VII**. This will be signed by the authorized signatory of the Bidder (s) with name, designation and seal of the Company at time of execution of formal agreement.

- 40.** Any corrigendum/date extension etc. in respect of above tender shall be issued in website <https://coalindiatenders.nic.in> only. No separate notification shall be issued in the press. Bidders are therefore requested to visit our website regularly to keep themselves updated.

40. Integrity Pact (applicable for tenders with estimated cost more than Rs. 200 lakhs).

Bidders are required to accept unconditionally the Pre-Contract Integrity Pact in GTE as per enclosed format, **Annexure VI**.

Name, address and contact No. of the Independent External Monitor (IEM) nominated for this tender:

Sl. No	Name	email Id
1	*Shri Sanjiv Garg, IRTS (Retired)	sanjivgarg.iem@gmail.com
2	*Shri Rohit Choudhary, IPS (Retd.)	aol.rohit@gmail.com

(*Note: Not to be the part of the Tender Document- The names of the Independent External Monitor(s) (IEMs) may be viewed, from time to time, under the *Integrity Pact Programme* section available in the Vigilance Section of the CCL website, and the same shall be updated accordingly.)

41. To & fro transportation of the materials/manpower/spares, if required, will be borne by the firm at their own cost if not specified in the BOQ/Price Bid.

42. Support/ Infrastructure to be provided by company: (to be defined case to case basis)

43. Guarantee/Warranty: -----**Working hrs or ----- months of operation** from the date of receipt & acceptance of repaired item/completed job, whichever is earlier against use of poor material and faulty workmanship. In case of premature failure of the job due to poor quality of workmanship, the same should be rectified at free of cost. In case the contractor fails to do the same, amount on pro rata basis for remaining period of guaranteed period will be deducted from your running/final/security deposit bills. In case of any failure on account of repairer to be decided by joint inspection, within guarantee/warranty period, the subject item/job will be redelivered after repair within half of the original delivery period from the date of joint inspection at the risk and cost of the repairer. However, this will be jointly inspected within 10 days or as the case maybe, after receipt of intimation by e-mail/fax/post etc, whichever is earlier, to the repairer. If the repairer does not turn up for the joint inspection within specified period then it will be presumed that, the repairer has accepted the warranty failure in its account. In case of failure of guarantee/warranty repair within the stipulated period i.e. half of the original delivery period, the LD will be deducted as stated at LD clause.

Note: Above clause may vary from case to case, depending upon the requirements of the job.

44. Additional Performance Security (APS)/ Abnormally Low Bids:

Additional Performance Security (APS) shall be applicable if the quoted price (excluding GST) is below 15% of the updated/justified cost (excluding GST) finalized by the Procuring Entity. The amount of such APS shall be the difference between 85% of the updated/justified cost (excluding GST) finalized by the Procuring Entity and quoted price (excluding GST).

The updated/justified cost is the estimated cost put to tender.

Additional Performance Security (APS) shall be furnished by the bidder along with normal Performance Security as per Clause No. 4 of GTC. In case the successful Bidder fails to submit the Additional Performance, Security, within the stipulated time, then the following actions shall be taken:

- i) Cancellation of award of work.
- ii) Forfeiture of the Earnest Money/Bid Security.

- iii) Any due amount to the contractor against the work done shall be treated as a part of the damages suffered by the company and shall not be paid to the contractor.
- iv) The Company shall debar such defaulting Contractor from participating in future tenders in concerned Subsidiary/CIL HQ for a period of minimum one year from the date of issue of such letter.

Note: However, debarment shall be done as per Guidelines on Debarment of firms from Bidding.

The validity of the Bank Guarantee shall be for a period of "one year" or "ninety days beyond the period of contract/extended period of contract (if any)", whichever is more.

This additional performance security will not carry any interest and shall be released in the following manner:

- i) 30% of Additional performance security will be released after 60% of the total work is completed.
- ii) 50% of Additional performance security will be released after 80% of the total work is completed.
- iii) 100% of Additional performance security will be released after total work is completed.

Additional performance security may be furnished in the shape of BG or any of the forms as applicable for performance security.

The validity of the Bank Guarantee if APS submitted in the form of BG shall be for a period of one year or ninety days beyond the period of contract /extended contract period (if any), whichever is more.

45. Period of Contract/ Period of Completion:

The period of contract is **(any suitable nos. of days)** from the date of commencement of Work Order/LOI/LOA. The repair work has to be completed in all respect within the stipulated period as mentioned in the NIT i.e. within ----- days from the date of handing over the job within contract period. The date of commencement of work shall be reckoned from 10th day from receipt of LOA/Work Order or from 7th day from the receipt of communication of handing over of job, whichever is later. Date of receipt of LOA/Work Order/Communication of Job Handover etc will be taken as date of receipt of same at bidder's end by e-mail/fax/post etc, whichever is earlier.

However, if required, management reserves the right to extend the period of work.

46. LD/ Penalty Clause: As per clause no 6 of condition of contract.

47. Inspection: The completed/repaired job will be inspected by the Engineer I/C or his representative at site in the presence of contractor. They have the right to reject the whole work or part thereof if it is found below standard.

48. Payment Terms – Payments of bills will be done within one month of presentation of bill duly passed and accepted by Engineer In-Charge.

49. All materials to be provided by the firm or issued by the company to the firm should be routed through Regional Stores of the respective Area and recorded in books. Only after inspection & acceptance of supplied material will be used for repair work with proper entry in register at con-

cerned section (if applicable). However, this clause may be exempted in special cases with the approval of TIA.

50. The contractor will be wholly responsible for the safe storage/custody of the materials received from the company. Any loss/damage to such store materials will be the contractor's account.

51. Submission of Bill:

- a) GST Registration Number of CCL (Central Coalfields Limited) for Projects located in Jharkhand is 20AAACC7476RHZT. Invoice issued by service provider should bear this number to enable CCL to claim INPUT TAX CREDIT.
- b) Service Provider will raise invoice strictly adhere as per the provision of section 31 of CGST Act, 2017 along with Rule 46 & 47 of CGST Rules, 2017.
- c) When there is any delay of payment against the invoice due to fault of service provider and if any reversal of input tax arises, the same will be recovered from service provider along with interest as paid by CCL due to reversal.
- d) Service provider will indicate the rate as well as amount of CGST, SGST or IGST in invoice.
- e) Service provider should also give an undertaking on invoice or as separate Annexure along with invoice that Invoice/applicable GST Returns has been/will be uploaded in GST Portal within due time as prescribed in CGST Act and has been deposited CGST, SGST or IGST as per the provision of GST Act and rules thereon.
- f) Service provider will file all the returns and details as applicable under GST Laws & Rules within due dates.
- g) Amount of statutory levies like CGST, SGST or IGST will be released when the same will appear in GSTR-2A of CCL in the common portal of GST and after submission of documentary evidence deposition of GST Taxes and filing of GST Returns.
- h) In case the GST rating of vendor on the GST Portal/Govt. Official website is negative/black listed at any stage even after award of work, CCL has right to reject the letter of award. NCL shall not be obligated or liable to pay or reimburse GST to such vendor and shall also be entitled to deduct/recover such GST along with all penalties/interest, if any, incurred by CCL.
- i) Service provider will issue credit note as per the provision of Rule 53 of CGST Rule, 2017 on quality deduction or liquidity damage, if any arises.
- j) If service provider default in uploading the invoice/uploading the applicable GST returns/deposit of applicable GST Taxes,CCL reserve the right to upload such defaulter on website and may also consider for giving holiday/debarring from participating tenders.

52. Adjustment of the Dues: If any sum found due from and payable to the company by the contractor in connection with any other contracts, the company shall have right and liberty to adjust the same out of the due under other contracts.

In case of onsite works, Attendance of manpower is to be recorded in the time office by the time keepers & is to be countersigned by concerned concern section I/c or his authorized representative. Firm has to submit list of their workmen along with copies of I-Card, Form "B/A", VTC training paper etc. as per mines rules/factory act in the time office and work related concern section office (as applicable).

(Tender Inviting Authority)

INSTRUCTION TO BIDDERS

1. SCOPE OF BIDDER

1.1 The **Central Coalfields Limited** (referred to as Employer in these documents) invites bids for the works as mentioned in the Bid Notice. The Bidders should submit Bids for all the works mentioned in the Notice.

1.2 The successful Bidder will be expected to complete the Work(s) by the Intended Completion period specified in the Bid document/Notice.

2. ELIGIBLE BIDDERS

2.1 The Invitation for Bids is open to all Bidders including an individual, proprietorship firm, partnership firm, company registered under Companies Act, any legal entity or joint ventures. The bidders shall be eligible to participate only if they fulfill the qualifying criteria laid down separately hereinafter.

2.2 Deleted

2.3 Joint Venture: Two or three companies/contractors may jointly undertake contract/contracts. Each entity will be jointly and severally responsible for completing the task as per the contract (applicable for bids having estimated cost above Rs.2 Crores).

Joint Venture details:

Name of all partners of a joint venture(not more than 3):

1. Lead partner
2. Partner
3. Partner

Note - The participating share of JV Partners shall be as below;

- i) Lead Partner shall have at least 50% participating share in JV.
- ii) Other partner(s) shall have at least 20% participating share in JV.

Joint Venture must comply the following requirements:

- i) Following are the minimum qualification requirements for Joint Venture
 - a) The qualifying criteria parameter e.g. experience of the individual partners of the J.V will be as deliberated under cl.3.3(A) of ITB towards fulfilment of qualification criteria related to experience.
 - b) The qualifying criteria parameter e.g. financial resources (Turnover) of the individual

partners of the J.V. will be added together, for the relevant period, and the total criteria should not be less than as deliberated under cl.3.3(B) of ITB towards fulfilment of qualification criteria related to financial turnover.

ii) The formation of joint venture or change in the Joint Venture character/ partners after submission of the bid and any change in the bidding regarding Joint Venture will not be permitted.

iii) The bid, and in case of a successful bid, the agreement, shall be signed so as to legally bind all partners jointly and severally and any bid shall be submitted with a copy of the Joint Venture Agreement providing the joint and several liabilities with respect to the contract.

iv) The pre-qualification of a Joint Venture does not necessarily pre-qualify any of its partners individually or as a partner in any other Joint Venture or association.

v) The bid submission must include documentary evidence to the relationship between Joint Venture partners in the form of JV Agreement to legally bind all partners jointly and severally for the proposed agreement which should set out the principles for the constitution, operation, responsibilities regarding work and financial arrangements, participation (percentage share in the total) and liabilities (joint and several) in respect of each and all of the firms in the Joint Venture. Such JV Agreement must evidence the commitment of the parties to bid for the facilities applied for (if pre-qualified) and to execute the contract for the facilities if their bid is successful.

vi) One of the partners shall be nominated for being in charge of the contract and shall be designated as Lead Partner. This authorization shall be evidenced by submitting with the bid a Power of Attorney signed by legally authorized signatories of all the partners.

vii) The JV Agreement must provide that the Lead Partner shall be authorized to incur liabilities and receive instructions for and on behalf of any and all partners of the Joint Venture and the entire execution of the contract shall be done with active participation of the Lead Partner.

viii) The contract agreement should be signed by each Joint Venture Partners. Subsequent declarations/ letters/ documents shall be signed by lead partner authorised to sign on behalf of joint venture or authorised signatory on behalf of JV.

ix) The bid should be signed/ digitally signed by the DSC holder submitting the bid.

x) An entity can be a partner in only one Joint Venture. Bid submitted by Joint Venture including the same entity as partner will be rejected.

xi) The JV agreement may specify the share of each individual partner for the purpose of execution of this contract. This is required to fulfill eligibility and also for the purpose of apportioning the value of the contract to that extent to individual partner for subsequent submission in other bids if he intends to do so for the purpose of the qualification in that Bid.

xii) The earnest money / Bids Security can be submitted by the Joint Venture / one or more partners of the joint venture.

xiii) The JV agreement must specifically state that it is valid for the project for which bidding is done. If JV breaks up mid-way before award of work and during bid validity period bid will be rejected.

If JV breaks up midway before award of work and during bid validity/after award of work/during pendency of contract, in addition to normal penalties as per provision of bid document, all the partners of the JV shall be debarred from participating in future bids for a minimum period of 12 months.

xiv) JV agreement shall be registered in accordance with law so as to be legally valid and binding on the members before making any payment.

xv) JV shall open a Bank Account in the name of JV and all payments due to the JV shall be credited by employer to that account only. To facilitate statutory deductions all statutory documents like PAN/GSTIN, etc. in the name of the Joint Venture shall be submitted by JV before making any payment.

2.4 The Company reserves its right to allow Public Enterprises purchase preference facility as admissible under prevailing policy.

2.5 No sub-letting of the work as a whole by the contractor is permissible. Prior permission is required to be taken from the principle employer for engagement of sub-contractors in part work/ piece rated work. The total value of subcontracted work should not exceed 25% of the contract price specified in the contract. Procurement of material, hiring of equipment or engagement of labour will not mean sub-contracting.

If a contractor submits his bid qualifies but does not get the contract because of his being not the lowest, he will be prohibited from working as a sub-contractor for the contractor who is executing the contract.

The Contract Agreement will specify major items of supply or services for which the contractor proposes to engage sub-contractor/sub-vendor. The contractor may from time to time propose any addition or deletion from any such list and will submit proposals in this regard to the Engineer-in-Charge/Designated Officer in charge for approval well in advance so as not to impede the progress of work. Such approval of the Engineer-in-Charge / Designated Officer in Charge will not relieve the contractor from any of his obligations, duties and responsibilities under the contract.

3. QUALIFICATION OF THE BIDDER

3.1 In the event that pre-qualification of potential bidders has been undertaken, only bids from pre-qualified bidders will be considered for award of contract.

3.2 If the employer has not undertaken pre-qualification of potential bidders, all bidders

shall fulfil the eligibility / qualifying criteria as detailed at Cl. No.8 & 9 of e-Tender Notice. Such details shall be submitted as deliberated at e-Tender Notice.

3.3 If the bidder is subsidiary of a company, the experience and resources of the holding company or its other subsidiaries will not be taken into account. However, if the bidder is a holding company, the experience and resources of its wholly owned subsidiaries will be taken into consideration.

3.4 Even though the bidders meet the above eligibility/qualifying criteria, they are subject to be disqualified if they have:

- a. Made misleading or false representations in the forms, statements and attachments submitted in proof of the qualification requirements.
- b. On account of currency of debarment as applicable.

4. ONE BID PER BIDDER

4.1 Each Bidder shall submit only one Bid, either individually, or as a proprietor, or as a partner in a partnership firm or as a partner in a joint venture or as a Company registered under Companies Act. A Bidder who submits or participates in more than one Bid (other than as a sub-contractor or in cases of alternatives that have been permitted or requested) will cause all the proposals with the Bidder's participation to be disqualified.

Earnest Money deposited by defaulting Bidders shall be forfeited and they shall be debarred from participating in future tenders in concerned Subsidiary/CIL HQ for a period of 12(twelve) months from the date of issue of such letter. In case of JV/Partnership firm, the debarment shall also be applicable to all individual partners of JV/Partnership firm.

5. COST OF BIDDING

5.1 The Bidder shall bear all costs associated with the preparation and submission of his Bid, and the Employer will in no case be responsible or liable for those costs.

6. SITE VISIT

6.1 The Bidder, at the Bidder's own responsibility, cost and risk, is encouraged to visit and examine the Site of Works and its surroundings, approach road, soil condition, investigation report, existing works, if any, connected to the tendered work, drawings connected to the work, if / as available and obtain all information that may be necessary for preparing the Bid and entering into a contract for execution of the Works. The costs of visiting the Site shall be at the Bidder's own expense.

6.2 It shall be deemed that the Bidder has visited the site/area and got fully acquainted with the working conditions and other prevalent conditions and fluctuations thereto whether he actually visits the site/area or not and has taken all the factors into account while quoting his rates.

6.3 The bidder is expected, before quoting his rate, to go through the requirement of materials / workmanship, specification, requirements and conditions of contract.

6.4 The bidder, in preparing the bid, shall rely on the site investigation report referred to in the bid document (if available), supplemented by any information available to the bidder

7. CONTENT OF BIDDING DOCUMENTS

7.1 The set of bidding documents comprises the documents listed in the table below as issued online by the Employer and addendum/corrigendum issued in accordance with relevant provision.

- a. Notice Inviting Tender
- b. Instructions to Bidders;
- c. Conditions of Contract; conditions, special notes and additional terms and conditions, safety norms etc.)
- d. Scope of work/Bill of Quantities;
- e. Forms of Securities and form of Article of Agreement.
- f. Pre contract Integrity Pact (if applicable)
- g. User portal Agreement
- h. Guidelines on Debarment of firms from Bidding
- i. Code of Integrity for Public Procurement (CIPP)
- j. Other document, if required.

8. CLARIFICATION OF BIDDING DOCUMENTS

8.1 The bidder may seek clarification on-line within the specified period. However, the management will clarify as far as possible to the relevant queries.

8.2 The pre-bid meeting if applicable shall be held in the office of Tender Inviting Authority, on the scheduled date & time, if specified in the NIT. The purpose of the pre-bid meeting is to clarify the issues and to answer the questions on any matter that may be raised at that stage. Non-attendance at the pre-bid meeting will not be a cause for disqualification of bidder and it shall be presumed that the bidder does not require any clarification. The management shall circulate proceedings of the pre-bid meeting, if held

9. AMENDMENT OF BIDDING DOCUMENTS (BE DELETED FOR NORMAL WORKS, APPLICABLE FOR SPECIALISED WORK)

9.1 Before the deadline for submission of Bids, the Employer may modify the bidding documents by issuing addenda.

9.2 Any addendum thus issued shall be part of the bidding documents and shall be displayed in the website.

9.3 To give prospective Bidders reasonable time in which to take an addendum into account in preparing their Bids, the Employer may extend, as necessary, the deadline for submission of Bids, in accordance with Sub-clause 18.2 below.

9.4 Bidders are requested to look into website for any addendum as specified in the NIT.

NOTE:-Instructions to bidders shall not incorporate this provision in the Bid for normal civil engineering works.

10. LANGUAGE OF BID

10.1 All documents relating to the Bid shall be in the English language.

11. Submission of Bid:

a. All the bids are to be submitted online on e-procurement portal of CIL. No bid shall be accepted offline.

b. In order to submit the Bid, the bidders have to get themselves registered online on the e-Procurement portal of CIL with valid Digital Signature Certificate (DSC) issued from any agency authorized by Controller of Certifying Authority (CCA), Govt. of India and which can be traced up to the chain of trust to the Root Certificate of CCA. The online Registration of the Bidders on the portal will be free of cost and one time activity only. The registration should be in the name of bidder, whereas DSC holder may be either bidder himself or his duly authorized person. The bidder is one whose name will appear as bidder in the e-Procurement Portal.

c. The bidders have to accept unconditionally the online user portal agreement which contains the acceptance of all the Terms and Conditions of NIT including General and Special Terms & Conditions, Integrity Pact and other conditions, if any, along with on-line undertaking in support of the authenticity of the declarations regarding the facts, figures, information and documents furnished by the Bidder on-line in order to become an eligible bidder. No conditional bid shall be allowed/accepted.

The bidders have to accept unconditionally in GTE (General Technical Evaluation) the Undertaking regarding Genuineness of the information furnished by him on-line & authenticity of the scanned copy of documents uploaded by him on-line in support of his eligibility criteria, etc. and Letter of Bid. No recycling will be done for this document i.e. no further clarification will be sought from bidder.

d. **Letter of Bid:** The format of Letter of Bid is given at Annexure I of Tender document. This will be the covering letter of the bidder for his submitted bid. The bidders have to accept unconditionally the Letter of Bid in GTE (General Technical Evaluation) at the time of bid submission. This online acceptance during bidding through GTE shall be construed as submission of LOB by bidder.

e. **Confirmatory Documents:** All the confirmatory documents as enlisted in the NIT in support of online information furnished by the bidder are to be uploaded in Cover-I & OID (Other Important Document, if applicable) by the bidder while submitting the bid online.

f. **Price Bid (in Cover-I/Cover-II):** The Price bid containing the Bill of Quantity will be in Excel format (password protected) and will be uploaded during tender creation. This will be downloaded by the bidder and he will quote the rates for all items on this Ex-

cel file. Thereafter, the bidder will upload the same Excel file during bid submission in Cover-I/Cover-II. The Price-bid will be in Item Rate/Percentage Rate BOQ format and the bidder will have to quote for all the tendered items and the L-1 will be decided on overall quoted value. The Price-bids of the tenderers will have no condition. The Price Bid which is incomplete and not submitted as per instruction given above will be rejected. Any alteration/modification in the Excel format may lead to rejection of bid.

12. BID PRICES

12.1 Deleted

12.2 The Bidder shall fill-in rates and prices for all items of the works described in the Bill of Quantities (both in words and figures) and amount(s) calculated and totaled.

12.3 All duties, taxes (excluding Goods and Services Tax (GST) & GST Compensation Cess (if applicable) only) and other levies, royalty, building and construction workers cess (as applicable in States) payable by the bidder/Contractor under the Contract, or for any other cause as applicable on the last date of submission of Bid, shall be included in the rates, prices and the total Bid Price submitted by the Bidder. Applicable GST, if any, either payable by bidder or by company under reverse charge mechanism shall be computed by system in BOQ sheet as per predefined logic.

All investments, operating expenses, incidentals, overheads, leads, lifts, carriages, tools and plants etc. as may be attendant upon execution and completion of works shall also be included in the rates, prices and total Bid price submitted by the bidder.

However, such duties, taxes, levies etc. which is notified after the last date of submission of Bid and/or any increase over the rate existing on the last date of submission of Bid shall be reimbursed by the company on production of documentary evidence in support of payment actually made to the concerned authorities.

Similarly if there is any decrease in such duties, taxes and levies the same shall become recoverable from the contractor. The details of such duties, taxes and other levies along with rates shall be declared by the bidder.

The item wise rate quoted by bidder shall be inclusive of all taxes, duties & levies but excluding GST & GST Compensation Cess, if applicable. The payment of GST and GST Compensation Cess by service availer (i.e. CIL/Subsidiary) to bidder/contractor (if GST payable by bidder/contractor) would be made only on the latter submitting a Bill/invoice in accordance with the provision of relevant GST Act and the rules made there under and after online filing of valid return on GST portal. Payment of GST & GST Compensation Cess is responsibility of the service provider/contractor.

Further, any GST credit note required to be issued by the bidder / contractor under the GST provisions should be issued within the time limit prescribed under the GST law.

However, in case bidder/contractor is GST unregistered bidder/dealer or GST registered

under composition scheme in compliance with GST rules, the bidder/dealer shall not charge any GST and/or GST Compensation Cess on the bill/invoice. In case of unregistered dealer/bidder, GST, if applicable will be deposited by CIL/Subsidiary directly to concerned authorities in terms with GST provisions.

Input tax credit is to be availed by CIL/Subsidiary as per rule.

If CIL/Subsidiary fails to claim Input Tax Credit(ITC) on eligible Inputs, input services and Capital Goods or the ITC claimed is disallowed due to failure on the part of supplier/vendor of goods and services in incorporating the tax invoice issued to CIL/Subsidiary in its relevant returns under GST, payment of CGST & SGST or IGST, GST (Compensation to State) Cess shown in tax invoice to the tax authorities, issue of proper tax invoice or any other reason whatsoever, the applicable taxes &cess paid based on such Tax invoice shall be recovered from the current bills or any other dues of the supplier/vendor along with interest, if any.

Note:

During the execution of the contract if the GST status of the bidder changes, then the payment of GST, if any, to the contractor will be made as per the GST status declared by the bidder during tender stage based on which cost to company has been ascertained or at actuals, whichever is lower.

12.4 The rates and prices quoted by the Bidder shall be fixed for the duration of the contract and shall not be subject to variations on any account except to the extent variations allowed as per the conditions of the contract of the bidding document.

13. CURRENCIES OF BID AND PAYMENT

13.1 The unit rates and prices shall be quoted by the Bidder entirely in Indian Rupees.

14. BID VALIDITY

14.1 Bid shall remain valid for a period not less than 120 days from the end date of bid submission. A bid valid for a shorter period shall be rejected by the Employer.

14.2 In exceptional circumstances, prior to expiry of the original time limit, the Employer may request that the bidders (all the responsive tenderers) may extend the period of validity for a specified additional period. The request and the bidder's responses shall be made in writing. A bidder may refuse the request without forfeiting his bid security. A bidder agreeing to the request will not be required or permitted to modify his bid.

15. BID SECURITY/EARNEST MONEY DEPOSIT

15.1 The bidder shall furnish, as part of his bid, a Bid Security/Earnest Money of the amount as shown in e-Tender Notice for this particular work. Bid Security/EMD will be required to be deposited in the form as deliberated below:

The bidder will have to make the payment of EMD through online mode only.

In Online mode the bidder can make payment of EMD either through net-banking from

designated Bank/s or through NEFT/RTGS from any scheduled Bank In case of payment through net-banking the money will be immediately transferred to CIL/Subsidiary's designated Account. In case of payment through NEFT/RTGS the bidder will have to make payment as per the Challans generated by system on e-Procurement portal before submission of bid. Bidder will be allowed to submit his/her bid only when the EMD is successfully received in CIL/Subsidiary account and the information flows from Bank to e-Procurement system.

Micro and Small Enterprises (MSEs) as defined in MSE Procurement Policy issued by Department of Micro, Small and Medium Enterprises (MSME) will be exempt from the payment of earnest money (applicable only for Services tenders).

In case of exemption of EMD the scanned copy of document in support of exemption will have to be uploaded by the bidder during bid submission. However, this option is to be enabled only in those cases where the exemption of EMD to some bidders is allowed as per NIT.

Demand Drafts/ Banker's cheque/ NEFT will be acceptable as Earnest Money/ Bid Security for tenders having estimated value below Rs. 2 lakhs.

15.2. Any bid, which has not been, submitted either with the requisite amount of EMD or the valid exemption document (as applicable) shall be summarily rejected by the employer as non-responsive.

15.3 The EMD of rejected bidders will be refunded at any stage directly to the account from where it had been received (except the cases where EMD is to be forfeited).

15.4 The Bid Security / EMD of successful bidder may be retained and adjusted with performance security / security deposit at bidder's option.

15.5 The Bid Security/Earnest Money may be forfeited:

- a. if the Bidder withdraws the Bid after the end date of Bid submission during the period of Bid validity / extended validity with mutual consent; or
- b. in the case of a successful Bidder, if the Bidder fails within the specified time limit to:
 - i. Sign the Agreement; or
 - ii. Furnish the required Performance Security

Additionally, the company shall debar such defaulting contractor from participating in future tenders in concerned Subsidiary/CIL HQ for a period of minimum one year from the date of issue of such letter.

In case of JV/Partnership firm, the debarment shall also be applicable to all individual partners of JV/Partnership firm.

15.6 The Bid Security/ EMD deposited with the Employer will not carry any interest.

15.7 No claim from the bidders will be entertained for non-receipt of the refund in any account other than the one from where the money is received.

15.8 If the refund of EMD is not received by the bidder in the account from which the EMD has been made due to any technical reason, then it will be paid through conventional system of e-payment. For this purpose, bidder should submit E-Mandate form in format provided by company.

15.9 In case the tender is cancelled then EMD of all the participating bidders will be refunded unless it is forfeited by the department.

15.10 If the bidder withdraws his/her bid online (i.e. before the end date of submission of tender) then his/her EMD will be refunded automatically after the opening of tender.

16. SIGNING OF BID

16.1 The contractor's bid will be digitally signed by DSC holder submitting bid online and it does not require any physical signature. However, if the Contractor's bid bears the physical signature in addition to the digital signature of DSC holder, it will be accepted without questioning the identity of person signing the bid.

16.2 If the bidder himself is the DSC holder bidding on-line then no document is required. However, if the DSC holder is bidding online on behalf of the bidder then the Power of Attorney or any sort of legally acceptable document for the authority to bid on behalf of the bidder is required.

17. Deleted

18. DEADLINE FOR SUBMISSION OF BIDS

18.1 Bids shall be submitted online on the e-procurement portal of CIL within the stipulated date and time.

18.2 The Employer may extend the deadline for submission of Bids by issuing a corrigendum or an amendment, in which case all rights and obligations of the Employer and the Bidders previously subject to the original deadline will then be subject to the new deadline.

18.3 If number of bids received online is found to be less than 03(three) on end date of bid submission then the following critical dates of the Tender will be automatically extended for a period of four days ending at 17.00 hrs::

- Last date of submission of Bid
- Last date of receipt of EMD
- Date of opening of Tender

If any of the above extended Dates falls on Holiday i.e. a non-working day as defined in the e-Procurement Portal then the same is to be rescheduled to the next working day.

This extension will be also applicable in case of receipt of zero bid.

Notes:

1. The validity period of tender should be decided based on the final end date of submission of bids.
2. The auto extension shall work on the basis of number of bids received only. (It may so happen that any of these bids may be eventually rejected during Tender Opening, Technical evaluation or further process of evaluation resulting the total number of valid bids becoming less than three.)
3. After extension, the tender shall be opened irrespective of available number of bids on the extended date of opening of tender.

19. LATE BIDS

19.1 No Bid shall be received by the e-procurement portal after the deadline or the extended deadline, as the case may be.

20. MODIFICATION AND WITHDRAWAL OF BIDS:

~~20.1 For Single Cover System:~~

20.2 For Two Part System:

20.2.1 Modification of the submitted bid shall be allowed on-line only before the deadline of submission of tender and the bidder may modify and resubmit the bid on-line as many times as he may wish.

20.2.2 Bidders may withdraw their bids online within the end date of bid submission and their EMD will be refunded. However, if the bidder once withdraws his bid, he will not be able to resubmit the bid in that particular tender. For withdrawal of bid after the end date of bid submission, the bidder will have to make a request in writing to the Tender Inviting Authority. Withdrawal of bid may be allowed till issue of work order/LOA with the following provision of penal action:

- a. If the request of withdrawal is received before online notification for opening of price bid, the EMD will be forfeited and bidder will be debarred for minimum 1 (one) year from participating in tenders in CIL/Subsidiary. The Price-bid of remaining bidders will be opened and the tender process shall go on.
- b. If the request of withdrawal is received after online notification for opening of price bid, the EMD will be forfeited and the bidder will be debarred for minimum 1 (one) year from participating in tenders in CIL/Subsidiary.

20.2.3 The Price-bid of all eligible bidders including this bidder will be opened and action will follow as under:

- i). If the bidder withdrawing his bid is other than L 1, the tender process shall go on.
- ii). If the bidder withdrawing his bid is L-1, then re-tender will be done.

Note:

i). In case of above, a letter will be issued to the bidder by Tender Inviting Authority with the approval of Tender Accepting Authority (in case Board is Tender Accepting Authority then with the approval of CMD), stating that the EMD of bidder is forfeited, and this

bidder is debarred for.....year from participating in tenders in CIL/Subsidiary. This letter will be circulated to all Areas and CIL/Subsidiary HQ. and the updated list will be maintained by all Tender Inviting Authority/Evaluators.

ii). Penal action against clause (a) & (b) above will be enforced from the date of issue of such order.

*Delete whichever is not applicable

21. BID OPENING

21.1 Tender will be decrypted and opened online by the “Bid Openers” with their Digital Signature Certificates on the prescheduled date & time of Tender Opening.

22. PROCESS TO BE CONFIDENTIAL

22.1 Information relating to the examination, clarification, evaluation and comparison of Bids and recommendations for the award of a contract shall not be disclosed to Bidders or any other persons not officially concerned with such process until the award to the successful Bidder has been announced. However, the Tender Status will be in public domain and anyone visiting the site can view it by identifying the tender.

It will be the bidder’s responsibility to check the status of their Bid online regularly, after the opening of bid till award of contract. Additionally, information shall also be sent by system generated e-mail and SMS at nodal points (Date of bid opening, Requisition for Clarification on Confirmatory document from bidder(s), award of work etc.). No separate communication will be required in this regard. Non-receipt of e-mail and SMS will not be accepted as a reason of non-submission of Confirmatory documents within prescribed time..

22.2 Any effort by a Bidder to influence the Employer's processing of Bids or award decisions may result in the rejection of his Bid.

22.3 From the time of bid opening to the time of contract award, no bidder shall contact the Procuring Entity on any matter related to the bid, except on request and prior written permission.

23. CLARIFICATION OF BIDS

23.1 To assist in the examination, evaluation, and comparison of Bids, the Employer may, at the Employer's discretion, ask any Bidder for clarification of the Bidder's Bid, including breakdowns of unit rates. The request for clarification and the response shall be in writing. To assist in the examination, evaluation, and comparison of Bids, the Employer may, ask any Bidder for clarification of the Bidder's Bid, including breakup of unit rates. The request for clarification and the response shall be in online mode.

23.2 In case the Tender Committee finds that there is some deficiency in uploaded documents corresponding to the information furnished online or in case corresponding document have not been uploaded by bidder(s) then the same will be specified online by Evaluator clearly indicating the omissions/shortcomings in the uploaded documents and indicating start date and end date allowing 7 days (7 x 24 hours) time for online re-

submission by bidder(s). The bidder(s) will get this information on their personalized dashboard under "Upload confirmatory document" link. Additionally, information shall also be sent by system generated email and SMS, but it will be the bidder's responsibility to check the updated status/information on their personalized dash board regularly after opening of bid. No separate communication will be required in this regard. Non-receipt of e-mail and SMS will not be accepted as a reason of non-submission of documents within prescribed time. The bidder(s) will upload the scanned copy of all those specified documents in support of the information/ declarations furnished by them online within the specified period of 7 days. No further clarification shall be sought from Bidder.

Seeking clarification shall be restricted to confirmation of submitted document/online information only and it should be only for one time for a period of upto 7 days. The clarification shall be taken in online mode in the e-Procurement portal of CIL only.

Note: The shortfall information/ documents should be sought only in case of historical documents which pre-existed at the time of the tender opening and which have not undergone change since then. These should be called only on basis of the recommendations of the TC. So far as the submission of documents is concerned with regard to qualification criteria, after submission of the tender, only related shortfall documents should be asked for and considered.

Not to be the part of tender document- For example, if the bidder has submitted a contract without its completion/ performance certificate, the certificate can be asked for and considered. However, no new contract should be asked for so as to qualify the bidder

23.3 No document presented by the bidder after closing date and time of submission of bid will be considered unless otherwise called for as per clause 23.2 above.

24. EXAMINATION OF BIDS AND DETERMINATION OF RESPONSIVENESS

24.1 Prior to the detailed evaluation of Bids, the Employer will determine whether each Bid:

- a. meets the eligibility criteria defined in Clause 3;
- b. has been properly signed;
- c. is accompanied by the required Bid security/ EMD Exemption Document (if applicable).
- d. is substantially responsive to the requirements of the Bidding documents.

24.2 A substantially responsive Bid is one which conforms to all the terms, conditions, and specifications of the Bidding documents without material deviation or reservation. A material deviation or reservation is one :

- a. which affects in any substantial way the scope, quality, or performance of the works;
- b. which limits in any substantial way, inconsistent with the Bidding documents, the Employer's rights or the Bidder's obligations under the

Contract; or

c. whose rectification would affect unfairly the competitive position of other Bidders presenting substantially responsive Bids.

24.3 If a Bid is not substantially responsive, it may be rejected by the Employer at its sole discretion.

25. Deleted

26. EVALUATION AND COMPARISON OF BIDS.

26.1 The Employer will evaluate and compare only the Bids determined to be substantially responsive in accordance with Clause 24. Price bid of the bidder will have no condition.

The price bid which is incomplete and not submitted as per instruction given in the bid document will be rejected.

26.2 The evaluation of Bid, by the Employer shall be done as per Bid Prices as submitted by the Bidder in online Mode and subsequently downloaded from the e-procurement portal of CIL.

26.3 The Employer reserves the right to accept or reject any Bid not conforming to the requirements of the Bidding documents.

26.4 No document presented by the bidder, after closing date and time of bid, will be taken into account by the evaluation committee unless otherwise called for during scrutiny / technical scrutiny by the tender committee as clarification. This however, will have no bearing with the price quoted in the price bid. If a bidder offers a rebate unilaterally after the end date and time of the bid submission, it will not be taken into account for evaluation purpose by the tender committee. But if that bidder emerges as the lowest evaluated, the rebate offer will be taken into account for determination of the total offer.

26.5 Bid evaluation shall be done after taking into consideration overall quoted price by the bidder and effect of Goods and Services tax (GST), GST Compensation Cess etc. as applicable. L1 will be decided based on cost to the company.

26.6 If the bid of the successful bidder is seriously unbalanced in relation to the estimate of the cost of work to be performed under the contract, the company may require the bidder to produce detailed price analysis for any or all items of the Bill of quantities to demonstrate the internal consistency of these prices with the construction method and the schedule proposed. Additional Performance Security is required to be submitted by the successful bidder, if prescribed at relevant provision of GTC.

~~**27. ABNORMALLY HIGH RATE & ABNORMALLY LOW RATE ITEMS.**~~

~~PROVISIONS FOR DEALING WITH VARIATIONS IN RESPECT OF ABNORMALLY HIGH RATE AND ABNORMALLY LOW RATE ITEMS.~~

~~The abnormally high rate items are those whose quoted rates are more than 20% of the justified rates decided by the owner.~~

~~The abnormally low rate items are those whose quoted rates are less than 20% of the justified rates decided by the owner.~~

~~In case of Item Rate Tenders, the revision of rates for (i) abnormally high rate items and (ii) abnormally low rate items, shall become operative under the following circumstances:-~~

~~For increase in quantity of more than 25% in respect of works executed below plinth level and 10% in respect of works executed above plinth level.~~

~~Quantity variation beyond the limit mentioned above shall be dealt by arriving at new rate based on prevalent market rate of materials and labour analysed as per standard analysis of rate of CPWD/NBO. Payment of extra quantity over the permitted quantity as explained above would be made on the basis of the new analysed rate.~~

~~The variation in quantity of abnormally low rate items for item rate tenders shall not be permitted below 25% for the items below plinth level and below 10% for the items above plinth level of the agreement schedule quantity, but in exceptional cases with written consent of Engineer in Charge arising out of technical necessity.~~

~~The above provisions shall be applicable for item rate tenders only and not applicable for percentage rate tenders for works based on standard schedule of rates of the company.~~

~~For the purpose of operation, the following works shall be treated as works related to foundation, unless otherwise defined in the contract.~~

- ~~a) For Buildings: All works up to 1.2 metres above ground level or up to floor 1 level whichever is lower.~~
- ~~b) For abutments, piers and well steining : All works up to 1.2m above the bed level.~~
- ~~c) For retaining walls, wing walls, compound walls, chimneys, overhead reservoirs / tanks and other elevated structures: all works up to 1.2 metres above the ground level.~~
- ~~d) For reservoirs / tanks (other than overhead reservoirs / tanks): All works upto 1.2 metres above the ground level.~~
- ~~e) For basement : all works up to 1.2m above ground level or up to floor 1 level whichever is lower.~~
- ~~f) For Roads, all items of excavation and filling including treatment of sub base.~~

28. AWARD CRITERIA

28.1 Subject to Clause 29, the Employer will award the Contract to the Bidder whose Bid has been determined to be substantially responsive to the Bidding documents and who has offered the lowest evaluated acceptable Bid Price, provided that such Bidder has been determined to be:

- a. eligible in accordance with the provisions of Clause 2; and
- b. qualified in accordance with the provisions of Clause 3.

29. EMPLOYER'S RIGHT TO ACCEPT ANY BID, NEGOTIATE AND TO REJECT ANY OR ALL BIDS

29.1 Notwithstanding Clause 28, the Employer reserves the right to accept, negotiate or reject any Bid, and to cancel the bidding process and reject all Bids, at any time prior to the award of Contract, without thereby incurring any liability to the affected Bidder or Bidders or any obligation to inform the affected Bidder or Bidders of the grounds for the Employer's action.

30. NOTIFICATION OF AWARD AND SIGNING OF AGREEMENT

30.1 The Bidder, whose Bid has been accepted, will be notified /communicated by the Employer electronically online on the e-procurement portal of CIL prior to expiration of the Bid validity period. This letter (hereinafter and in the Conditions of Contract called the "Letter of Acceptance") will state the sum that the Employer will pay the Contractor in consideration of the execution and completion of the Works by the Contractor as prescribed by the Contract (hereinafter and in the Contract called "the Contract Price").

The offline communication of LOA shall not be mandatory.

30.2 The notification of award (LOA/Work Order) will constitute the formation of the Contract.

The works should be completed as per period specified in the NIT from the Date of Commencement as defined in Clause 6.0 of General Terms and Condition.

30.3 The Agreement will incorporate all agreements between the Employer and the successful Bidder, work programme etc. within 30(thirty)days following the notification of award along with the letter of Acceptance and / or Work Order issued by department.

In case of failure to enter in to agreement within specified period or extended period on the written request of the bidder, if any, the department will take action as prescribed in Guidelines on Debarment of firms from Bidding along with forfeiture of Earnest Money. The bidder will also debarred from participating in re-tender.

No payment for the work shall be made before execution of this agreement.

30.4 In the bidding process, the cause of rejection of Bid of any bidder shall be intimated to non-qualified bidder online and the Earnest Money shall be refunded to unsuccessful bidders as per relevant clauses.

30.5 The contractor shall enter into and execute contract agreement in the prescribed form on non-judicial stamp paper in accordance with the relevant law of the State/Union of India. The cost of the stamp papers for the contract agreement shall be

borne by the contractor. Two sets of contract document/agreements shall be prepared and signed by both the parties One of the sets shall be stamped "Original" and the other "Duplicate". The duplicate copy will be supplied to the contractor free of cost and the original is to be retained by the company. For any additional copy, additional cost to be charged.

All additional copies should be certified by the Engineer-in-Charge.

The contractor shall keep copy of these documents on the site/place of work in proper manner so that these are available for inspection at all reasonable times by the Engineer-in-charge, his representatives or any other officials authorized by the company for the purpose.

The contract document shall not be used by the contractor for any purpose other than this contract and the contractor shall ensure that all persons employed for this contract strictly adhere to this and maintain secrecy, as required of such documents.

31. PERFORMANCE SECURITY/SECURITY DEPOSIT

31.1 Security Deposit shall consist of two parts;

- a) Performance Security to be submitted at award of work and
- b) Retention Money to be recovered from running bills.

The security deposit shall bear no interest.

For details refer cl.4 of General Terms of Conditions

32. EMPLOYMENT OF LABOUR

32.1 Contractors are to employ, to the extent possible (as per policy decision of the company valid from time to time), local project affected people and pay wages not less than the minimum wages as per minimum Wages Act or such other legislations or award of the minimum wage fixed by respective State Govt. or Central Govt. as may be in force.

Payment of Provident Fund for the workmen employed by him for the work as per the Law prevailing under provision of CMPF/EPF and allied scheme valid from time to time shall be responsibility of the contractor.

The contractor needs to ensure that the employee has become a member of any of the provident fund as the case may be and the unique membership number of the CMPF/EPF or Allied Scheme needs to be submitted to Employer.

In addition to the above, the Contractor shall provide a copy of the updated passbook having entry made in the CMPF/EPF or Allied Scheme(s) of Provident fund as the case may be by the competent authority annually /as and when asked. Bidder shall also submit copies of statutory returns.

Payable statutory payments like PF & ESI contributions paid to the contract workers as applicable shall be reimbursed to the contractor on production of proof of payment limited to the maximum likely number of workmen to be deployed as indicated in the

tender document. Such payments shall be made on quarterly basis and shall not be included in the Contract Value.

32.2 The bidder shall also comply with statutory requirements of various acts including CL(R&A) Act.

32.3 The contractor's workmen shall be paid through Bank.

32.4 The contractors shall register themselves on the Contract Labour Payment Management Portal (CLPMP) of CIL within 30 days of issue of work order and will have to enter and update periodically the following details in the portal:

a. Work Order details

b. Details of Contractor workers and payment of wages in respect of each Work Order each month.

32.5 All the contract workers shall be covered with the Bio-metric attendance system for payment of wages.

NOTE: In case company decides/ circulates separate wages for underground works / for works within mine premises, the same may be allowed based on appropriate circular. Clause 32.1 shall stand amended to this extent before notification of bid.

33. LEGAL JURISDICTION

33.1 Matter relating to any dispute or difference arising out of this Bid and subsequent contract awarded based on the bid shall be subject to the jurisdiction of local court only where the subject work is to be executed.

34. DOWNLOADING BID DOCUMENT FROM WEB-SITE.

i) The bidders will download the Bid documents from the website. The company shall not be responsible for any delay/ difficulties/ inaccessibility of the downloading facility for any reason whatsoever. The downloading facility shall be available as soon as the bid is notified.

ii) The bid document as available online on the e-procurement of CIL shall always prevail and will be binding on the Bidders. Any claim on account of any deviation with respect to this online Bid document from the Bidder side shall not be entertained.

35. E-PAYMENT

Successful bidder(s) are required to submit an Authorization form duly signed for e-payment to them in the enclosed Annexure.

36. INTEGRITY PACT (APPLICABLE FOR BIDS WITH ESTIMATED COST EXCEEDING (more than Rs. 200 lakhs/ as decided by CIL/ Subsidiary).

Bidders are required to accept unconditionally in GTE (General Technical Evaluation) the

pre-contract integrity pact as per enclosed format along with the bid.

37. CHANGES IN FIRMS CONSTITUTION TO BE INTIMATED

Prior approval in writing of the Company shall be obtained before any change is made in the constitution of the contracting agency. If prior approval is not obtained the same will be treated as a breach of contract.

38. MISCELLANEOUS.

The bidders should fill the bid document properly and carefully. They should avoid quoting absurd rates. Throughout the bidding documents, the terms 'bid' and 'tender' and their derivatives are synonymous. Provisions related to instructions to bidder shall be a part of agreement.

39. Safety issues:

Contractor will be responsible for safety of their manpower deployed. They will provide all safety appliances and gadgets to their workers and ensure that their workers give top priority to safe working practices. Safety is not to be compromised under any circumstances as this is a statutory requirement. No work person shall be deployed by contractor without wearing safety appliances.

40. Gate Pass for to and fro movement of vehicle, tools and tackles, all items to be used at Site: Proper entry shall be made in the register on mine entry gate during entry and exit time. Competent authority of the projects will facilitate timely issue of gate passes for above purpose.

41. Payment of Contractors Workers through Bank: The contractor should facilitate opening of Bank account for his workers and to ensure payment through Bank only.

42. VTC Training (if applicable): VTC Training is a statutory requirement concerning the safety of contractor's labourers and for any work within Mines Area. Only VTC trained labour shall be deployed by the contractor. The contractor shall follow all law/ guidelines in this regard and arrange for VTC training in respect of his workers who are not VTC Trained.

43. No work person shall be deployed in mines, unless until he has gone through IME/PME (as applicable).

44. No work person shall be deployed in mines, unless until he has been enrolled in form –B register and having valid VTC and attendance has been marked in Form-D register/form E-register.

@@@@@

CONDITION OF CONTRACT

GENERAL TERMS AND CONDITIONS

1. Definitions

- i. The word "**Employer**" or "**Company**" or "**Owner**" wherever occurs in the conditions, means the Coal India Limited / **Subsidiary**, represented at Head Quarters of the Company by the General Manager (Excavation) or his authorized representatives or any other officer specially deputed for the purpose who will employ the contractor.
- ii. The word "Principal Employer" wherever occurs, means the officer nominated by the Company to function on its behalf.
- iii. Bid" (including the term 'tender', 'offer', 'quotation' or 'proposal' in certain contexts) means an offer to supply goods, services or execution of works made in accordance with the terms and conditions set out in a document inviting such offers.
- iv. "Bidder" (including the term 'tenderer', 'consultant' or 'service provider' in certain contexts) means any eligible person or firm or company, including a Joint Venture (that is an association of several persons, or firms or companies), participating in a procurement process with a Procuring Entity.
- v. "Bid security" (including the term 'Earnest Money Deposit'(EMD), in certain contexts) means a security from a bidder securing obligations resulting from a prospective contract award with the intention to avoid: the withdrawal or modification of an offer within the validity of the bid, after the deadline for submission of such documents; failure to sign the contract or failure to provide the required security for the performance of the contract after an offer has been accepted; or failure to comply with any other condition precedent to signing the contract specified in the tender documents.
- vi. "Class-I local supplier" means a supplier or service provider, whose goods, services or works offered for procurement, meets the minimum local content as prescribed for 'Class-I local supplier' under the Public Procurement (Preference to Make in India), Order 2017.
- vii. "Class-II local supplier" means a supplier or service provider, whose goods, services or works offered for procurement, meets the minimum local content as prescribed for 'Class-II local supplier' but less than that prescribed for 'Class-I local supplier' under the Public Procurement (Preference to Make in India), Order 2017.
- viii. "Local Content" means the amount of value added in India which shall, unless otherwise prescribed by the Nodal Ministry, be the total value of the item procured (excluding net domestic indirect taxes) minus the value of imported content in the item (including all customs duties) as a proportion of the total value, in percent.
- ix. "Non-Local supplier" means a supplier or service provider, whose goods, services or works offered for procurement, has local content less than that prescribed for 'Class-II local supplier' under the Public Procurement (Preference to Make in India), Order 2017.
- x. "Notice inviting tenders" (including the term 'Invitation to bid' or 'request for proposals' in certain contexts) means a document and any amendment thereto published or notified by the Procuring Entity, which informs the potential bidders that it intends to procure goods, services and/or works.

- xi. "Prospective bidder" means anyone likely or desirous to be a bidder.
- xii. "Procurement contract" (including the terms 'Purchase Order' or 'Supply Order' or 'Withdrawal Order' or '**Work Order**' or 'Consultancy Contract' or 'Contract for other services' under certain contexts), means an agreement relating to the subject matter of procurement, entered into between the Procuring Entity and the supplier, service provider or contractor on mutually acceptable terms and conditions and which are in compliance with all the relevant provisions of the laws of the country. The term "contract" will also include "rate contract' and "framework contract".

The agreement shall include the notice inviting tender, the tender/bid as accepted by the company, the work order issued to the contractor, and the formal contract agreement executed between the company and the contractor together with the documents referred to therein including general terms and conditions, special conditions, if any, frozen terms and conditions/technical parameters/scope of work and revised offer, if any, specifications, drawings, including those to be submitted during progress of work, schedule of quantities with rates and amounts.

Until the formal agreement is signed between the Owner and contractor, LOA/Work order together with contract document accepted by the bidder (i.e., bid/ tender/ proposal/ offer) shall constitute the contract

- xiii. The word "**Contractor/ Contractors**" wherever occurs means the successful bidder /bidders who has/have deposited the necessary Earnest money and has/have been given written intimation about the acceptance of tender and shall include legal representative of such individual or persons composing a firm or a company or the successors and permitted assignees of such individual, firm or Company, as the case may be and any constitutional, or otherwise change of which shall have prior approval of the employer.
- xiv. "**Site**" means the land and places including location of Project/Plant/HEMM/sub assembly thereon, over, under, in or through which the Permanent works or Temporary works designed by the Engineer-in-Charge are to be executed and any other lands and places provided by the Employer for working space or any other purpose as may be specifically designated in the Contract as forming part of the site.
- xv. The term "**Sub-Contractor**" as employed herein, includes those having a direct contract with Contractor either on piece rate, item rate, time rate or any other basis and it includes one who furnishes work to a special design according to the plans or specifications of this work but does not include one who merely supplies materials.
- xvi. "**Accepting Authority**" shall mean the management of the company and includes an authorized representative of the company or any other person or body of persons empowered on its behalf by the company.
- xvii. "**Engineer-in-charge**" shall mean the officer nominated by the company in the Excavation cadre/ discipline who is competent to direct supervisors and authorised to be in charge of the works for the purpose of this contract. The Engineer-in-Charge /Designated Officer in Charge, who is of an appropriate seniority, will be responsible for supervising and administering the contract, certifying payments due to the contractor, valuing variations to the contract, awarding extension of time and valuing compensation events. The Engineer-in-Charge/Designated Officer in Charge may further appoint his representatives i.e. another person/Project Manager or any other competent person and notify to the contractor who is directly responsible for supervising the work being executed at the site, on his behalf under their Delegation of Powers of the company. However, overall responsibility, as far as the contract is concerned, will be that of the Engineer-in-Charge/Designated Officer in Charge.
- xviii. A "**Day**" shall mean a day of 24 hours from midnight to midnight.
- xix. The "**Work**" shall mean the works required to be executed in accordance with the

- contract/work order.
- xx. **"Schedule of Rates"** Estimated and finally accepted.
 - xxi. **"Contract amount"** shall mean: In the case of contracts the total sum for which tender is accepted by the company **inclusive of applicable GST** .
 - xxii. **"Written notice"** shall mean a notice or communication in writing and shall be deemed to have been duly served if delivered in person to the individual or to a member of the contractors firm or to an office of the company for whom it is intended, or if delivered at or sent by registered mail/e-mail to the last business address known to him who gives the notice.
 - xxiii. **"The constructional plant"** means all appliances, tools, plants or machinery of whatsoever nature required in or about the execution, completion or maintenance of the works but does not include materials or other things intended to form part of the permanent work.
 - xxiv. **"Letter of Acceptance of Tender"** means letter giving intimation to the tenderer that his tender has been accepted in accordance with the provisions contained in that letter.
 - xxv. **"Department"** means the Excavation Department of Coal India Limited or any of its subsidiary companies/units represented by the appropriate authority.
 - xxvi. The words indicating the singular only also include the plural and vice-versa where the context so requires.
 - xxvii. **"Codes"** shall mean the following, including the latest amendments, and/or replacements, if any :
 - a) Bureau of Indian Standards relevant to the works under the contract and their specifications.
 - b) Indian Electricity Act and Rules and Regulations made there under.
 - c) Indian Mines Act and Rules and Regulations made there under.
 - d) Any other Act, rule and regulations applicable for employment of labour, safety provisions, payment of Provident fund and compensation, insurance etc.

2. Contract Documents and Miscellaneous Provisions:

The following documents shall constitute the contract documents:

- i) Articles of Agreement.
- ii) Letter of Acceptance of Bid/ Work Order indicating deviation, if any, from the conditions of contract incorporated in the tender document issued to the bidder.
- iii) Notice Inviting Tender and Instructions to Bidders.
- iv) Conditions of Contract including General Terms & Conditions of contract, Additional Terms & Conditions, Special Terms & Conditions and Commercial Terms & Conditions etc.- as applicable.
- v) Frozen terms & conditions / technical parameters and revised offer, if any.
- vi) Specifications/ scope of Work, if any.
- vii) Schedule of quantities (or Bill of Quantities) along with accepted rate.
- viii) Contract drawings and work programme.
- ix) Safety Code etc. forming part of the tender,
- x) Integrity Pact (If applicable).
- (xi) Guidelines on Debarment of firms from Bidding.
- (xii) Code of Integrity for Public Procurement (CIPP)
- (xiii) Any other document if required.

2.1The contractor shall enter into and execute contract agreement in the prescribed form. The cost of the stamp papers for the contract agreement shall be borne by the contractor. Two sets of contract document/agreements shall be prepared and signed by both the parties One of the sets shall be stamped "Original" and the other "Duplicate".

The duplicate copy will be supplied to the contractor free of cost and the original is to be retained by the company. For additional copy, cost to be charged.

All additional copies should be certified by the Engineer-in-Charge.

The contractor shall keep copy of these documents on the site/place of work in proper manner so that these are available for inspection at all reasonable times by the Engineer-in-charge, his representatives or any other officials authorized by the company for the purpose.

2.2 The contract document shall not be used by the contractor for any purpose other than this contract and the contractor shall ensure that all persons employed for this contract strictly adhere to this and maintain secrecy, as required of such documents.

2.3 The local Court, where the subject work is to be executed shall have exclusive jurisdiction in all matter arising under this contract.

2.4 The Contract Agreement will specify major items of supply or services for which the contractor proposes to engage sub-contractor/sub-vendor. The contractor may from time to time propose any addition or deletion from any such list and will submit proposals in this regard to the Engineer-in-Charge / Designated Officer in charge for approval well in advance so as not to impede the progress of work. Such approval of the Engineer-in-Charge / Designated Officer in Charge will not relieve the contractor from any of his obligations, duties and responsibilities under the contract. The total value of subcontracted work should not exceed 25% of the contract price specified in the contract. Procurement of material, hiring of equipment or engagement of labour will not mean sub-contracting.

2.5 Acceptance of Offer:

“Letter of Acceptance”- is an acceptance of offer by the company. It shall be communicated electronically through e-procurement portal of CIL to the successful bidder and shall make the binding Contract with the Company.

Simultaneously the original copy of LOA may also be sent to the Bidder through registered/speed post. The offline communication of LOA, shall not be mandatory.

3. Discrepancies in contract documents & Adjustments thereof

The documents forming part of the contract are to be treated as mutually explanatory of one another and in case of discrepancy between schedule of quantity, the specifications and/or drawing, the following order of preference shall be observed;

- a) Description in Bill of Quantities of work.
- b) Particular specification and special conditions, if any
- c) Drawings.
- d) General specifications.

3.1 In the event of varying or conflicting provision in any of the document(s) forming part of the contract, the Accepting Authority's decision/clarification shall hold good with regard to the intention of the document or contract as the case may be.

3.2 Any error in description, quantity or rate in Bill of Quantities or any omission there from, shall not vitiate the contract or release the contractor from discharging his obligations under

the contract including execution of work according to the Drawings and Specifications forming part of the particular contract document.

4.00 Security Deposit:

4.1 Security Deposit shall consist of two parts;

- a) Performance Security to be submitted at award of work and
- b) Retention Money to be recovered from running bills.

The security deposit shall bear no interest.

4.2 Performance Security should be 5% of contract amount excluding GST and should be submitted **within 21 days of issuance** of LOA by the successful bidder in any of the form given below:

- Payment through NEFT/RTGS in the designated account of CIL/Subsidiary as indicated in the LOA/WO.
- a Bank Guarantee in the form given in the bid document from any Scheduled Commercial bank (i.e. Indian or Foreign Banks included in the Second Schedule of Reserve Bank of India Act, 1934 excluding Co-operative banks or Regional Rural Banks). The BG issued by outstation bank shall be operative at its local branch at or branch at.....
Bank Guarantee against Performance Security shall be applicable if the amount of Performance Security exceeds Rs. 5.0 lakhs.
- Govt. Securities, FDR or any other form of deposit stipulated by the owner and duly pledged in favour of owner.

However, Company may approve submission of Performance Security beyond 21 days by another 14 days with proper justification on a case to case basis.

The Earnest Money/ Bid Security deposited is to be returned to the contractor after submission and acceptance of Performance Security.

The bid security deposited may be adjusted against the Performance security (1st part of security deposit) at bidder's option.

If performance security is provided by the successful bidder in the form of bank guarantee it shall be issued either –

- (a) at Bidder's option by a Scheduled Commercial Bank , or
- (b) by a foreign bank located in India and acceptable to the employer.

BG of scheduled commercial bank located in India and acceptable to the company should only be accepted. Thus, any BG issued by foreign bank from outside India shall not be accepted.

The validity of the Bank Guarantee shall be for a period of one year or ninety days beyond the period of contract /extended contract period (if any), whichever is more.

The BG (If performance security is provided by the successful bidder in the form of bank guarantee) issued by issuing bank on behalf of the bidder in favour of " _____," shall be in paper form (Stamp Paper) as well as issued under "Structured Financial Messaging System". Issuing Bank should send the underlying confirmation message in IFN760COV or IFN767COV message type for getting the BG advised through our bank. Also issuing bank should mention " _____" in field no. "7037" of IFN760COV or IFN767COV. The message will be sent to the beneficiary bank through SFMS. The details of beneficiary

Bank for issue of BG through SFMS Platform is furnished below:-

Name of Bank: _____

Branch: _____

IFSC Code: _____

Account No. _____

Customer ID: _____

Original copy of the Bank Guarantee issued by the Issuing Bank shall be sent by the issuing bank to **Excavation Department** of (CIL/Subsidiary).

In case the successful Bidder fails to submit the Performance Security within the stipulated time then the following actions shall be taken:

- i. Cancellation of award of work
- ii. Forfeiture of the Earnest Money/ Bid Security
- iii. Any due amount to the contractor against the work done shall be treated as a part of the damages suffered by the company and shall not be paid to the contractor.
- iv. The Company shall debar such defaulting Contractor from participating in future tenders in concerned Subsidiary/CIL HQ for a period of minimum one year from the date of issue of such letter. In case of JV/Partnership firm, the debarment shall also be applicable to all individual partners of JV/Partnership firm

When validity of BG is about to expire, the contractor has to extend the validity of BG, if required. If the validity of BG is not extended before 03 days of its expiry, then CIL/ Subsidiary shall be at liberty to encash the BG.

In case of a JV, the Performance Security can be submitted by the Joint Venture / one or more partners of the joint venture.

Submission of Performance Security is not required for tenders having Estimated Value put to tender upto Rs. 2.00 lakhs (incl. GST). In this case, EMD of successful bidder shall be released within 14 days of the issue of defect liability certificate (taking over certificate with a list of defects)/ warranty/ guarantee completion certificate.

4.3 Performance Security should be refunded within 14 days of the issue of defect liability Certificate (taking over certificate with a list of defects)/**completion of warranty/guarantee period.**)

4.4 5% of work value excluding GST shall be retained from all running on account bills. This shall be treated as retention money and will be second part of security deposit.

Retention Money may be refunded against equivalent Bank Guarantee, on written request of the contractor, on its accumulation to a minimum amount of Rs 25 lakhs subject to the condition that amount of any Bank Guarantee except last one, shall not be less Rs. 25 lakhs. However, Bank Guarantee against retention money shall be with suitable validity based on nature of work which shall be 90 days beyond the defect liability period/warranty period, but in no case less than the period of one year.

Bank Guarantee is to be submitted in the format prescribed by the company. Bank Guarantee shall be irrevocable and will be from Scheduled Banks as elaborated at Clause 4.2.

4.5 Retention Money should be refunded after issue of No Defect Certificate/completion of warranty/guarantee period.

4.6 The Company shall be at liberty to deduct/appropriate from the security deposit such sums as are due and payable by the contractor to the company as may be determined in terms of the contract, and the amount appropriated from the security deposit shall have to be restored by further deduction from the contractors subsequent on account running bills, if any.

4.7 REFUND OF SECURITY DEPOSIT: The refund of security deposit shall be subject to company's right to deduct/ appropriate its due against the contractor under this contract or under any other contract.

On completion of the entire work and issue of defect liability certificate (taking over certificate with a list of defects) by the Engineer-in-charge, one half of the security deposit remaining with the company

(Performance Security) shall be refunded as elaborated at Cl. No.4.3.

The other half (Retention Money) shall be refunded to the contractor after issue of No Defect Certificate/ **completion of warranty/guarantee period** by the Engineer-in-Charge on the expiry of Defect Liability Period of six months/ **completion of warranty/guarantee period** , subject to the following conditions:

a) Any defect/defects in the work, if detected after issue of defect liability certificate (Taking over certificate with list of defects) is/are rectified to the satisfaction of the Engineer-in-Charge within the said defect liability period of six months or on its due extension till completion of the rectification works as required.

b) In case of Maintenance contracts, that ends with successful completion of work, where question of Defect Liability Period/ **completion of warranty/guarantee period** does not arise (e.g. sweeping, up-keeping, washing / cleaning, material handling/ mounting demounting work etc.), the performance security and retention money (second part of bid security) can be released simultaneously after completion of work and taking over by department.

4.8 Additional performance security: (applicable for item rate as well as percentage rate tenders):

Additional Performance Security (APS) shall be applicable if the quoted price (excluding GST) is below 15% of the updated/justified cost (excluding GST) finalized by the Procuring Entity. The amount of such APS shall be the difference between 85% of the updated/justified cost (excluding GST) finalized by the Procuring Entity and quoted price (excluding GST). The updated/justified cost is the estimated cost put to tender.

Additional Performance Security (APS) shall be furnished within 21 days of issuance of LOA by the successful bidder along with normal Performance Security as per Clause No. 4 of GTC. Additional performance security may be furnished in the shape of BG or any of the forms as applicable for performance security.

In case the successful Bidder fails to submit the Additional Performance Security within the stipulated time then the following actions shall be taken:

- i) Cancellation of award of work.
- ii) Forfeiture of the Earnest Money/Bid Security.
- iii) Any due amount to the contractor against the work done shall be treated as a

part of the damages suffered by the company and shall not be paid to the contractor.

- iv) The Company shall debar such defaulting Contractor from participating in future tenders in concerned Subsidiary/CIL HQ for a period of minimum one year from the date of issue of such letter. In case of JV/Partnership firm, the banning shall also be applicable to all individual partners of JV/Partnership firm.

Note: However, debarment shall be done as per Guidelines on Debarment of firms from Bidding.

The validity of the Bank Guarantee shall be for a period of "one year" or "ninety days beyond the period of contract/extended period of contract (if any)", whichever is more.

This Additional Performance Security will not carry any interest and shall be released in the following manner:

- i. 30% of Additional Performance Security will be released after 60% of the total work is completed.
- ii. 50% of Additional Performance Security will be released after 80% of the total work is completed.

100% of Additional Performance Security will be released after total work is completed

Consideration of Abnormally Low Bids

In case of Abnormally Low Bid, CIL/ Subsidiary may in such cases seek written clarifications from the lowest bidder(s), including detailed price analyses of its bid price in relation to scope, schedule, allocation of risks and responsibilities, and any other requirements of the bid documents. If, after evaluating the price analysis, CIL/ Subsidiary determines that the bidder(s) has substantially failed to demonstrate its capability to deliver the contract at the offered price, CIL/ Subsidiary may reject the bid/ proposal.

~~5. Deviations/Variations in Quantities and Pricing.~~

~~The quantities given in the "Schedule of Quantities" are based on estimates and are meant to indicate the extent of the work and to provide a uniform basis for tendering and any variation either by addition or omission shall not vitiate the contract.~~

~~5.1 The company through its Engineer in Charge or his representative shall, without radically changing the original scope and nature of the work, under contract, have power to make any alterations in or additions to or substitution of the original specifications, drawings, designs and instructions that may appear to be necessary or advisable during the progress of the work.~~

~~The contractor shall be bound to carry out the work(s) in accordance with the instructions given to him in writing by the Engineer in Charge or his representative on behalf of the company. Such altered or additional or substituted work, which shall form part of the original contract, shall be carried out by the contractor on the same terms and conditions in all respects on which they agreed to do the main work and at the same rate/rates as are specified in the contract/ work order.~~

~~5.2 The right is reserved to cancel any items of work included in the contract agreement or portion thereof in any stage of execution if found necessary to the work and such omission shall not be a waiver of any condition of the contract nor invalidate any of the provisions~~

thereof.

~~5.3 If the additional, altered or substituted work includes any class of work for which rate/rates is/are not specified in the contract/work order, rates for such items shall be determined by the Engineer in Charge as follows:~~

~~a) In the case of percentage tenders, if the rate for the extra item of work executed is available in the company's approved SOR, it will be paid at the schedule rate plus or minus the accepted percentage as per contract.~~

~~However, if the extra item is not available in company's approved SOR, then the rate for such extra item(s) shall be dealt as at (c) below.~~

~~b) In case of item rate tenders, the rate for extra item shall be derived from the rate for similar item or near similar item / class of work available in the agreement schedule of work or by analysis of rates as at below and the lower rate out of the above two shall be considered.~~

~~In case of composite item rate tenders, where two or more schedule of quantities for similar item description may form part of the contract, the applicable rates shall be taken from the Schedule of Quantities of that particular part in which the deviation is involved, failing that at the lowest applicable rate for the similar item of work in the other schedule of quantities. For derivation of rates based on analysis, the same shall be done by analysis on prevalent market rate of materials and labour based on standard norms of analysis of rate of C.P.W.D/ N.B.O.~~

~~e) In the case of extra item(s) that are completely new, and are in addition to the items contained in the contract, the contractor may within 15 days of receipt of order or occurrence of the item(s) claim rates, supported by proper analysis. The Engineer in Charge shall determine the rate(s) by analysis based on prevalent market rate of material and labour and on standard norms of analysis of rate of CPWD / NBO.~~

~~d) In case of combined tender with partly item rate for non-schedule items & partly percentage tenders for SOR items, the rate for extra item shall be derived as at (b) & (c) above in case of non-schedule items rates and in case of percentage rates for SOR items the rate for extra item shall be derived as at (a) above.~~

~~In case of any difference between the contractor and the Engineer In Charge as to the fixation of rates, the matter shall be referred to the accepting authority of the company i.e. GM(C) of the company or Staff Officer(C) for the work awarded at Company Hqrs. level and Area level respectively, whose decision shall be final and binding on the contractor.~~

~~5.4 Alteration in the quantities shall not be considered as a change in the condition of the contract nor invalidate any of the provision thereof provided that a deviation estimate / revised estimate/supplementary agreement for the item(s) involved is made. Such approval shall be from appropriate authority.~~

~~5.5 Payment for such deviated items [additional/ altered / substituted items of work of the agreement schedule] shall be made in the contractors running on account bills, till the revised estimate / deviation estimate regularizing these items are sanctioned by the competent authority of the company, at the provisional rates and shall not exceed:~~

a) 75% of the rate recommended by the Engineer in Charge to the accepting authority of the company i.e. GM(C) of the company or SO(C) of the Area, if the rate is directly available in the SOR of the company/ if the rate is derived from available rate of BOQ.

b) 50% of the rate recommended by the Engineer in Charge to the accepting authority of the company, i.e. GM(C) of the company or SO(C) of the Area, if it is analysed item rates based on prevalent market rates of materials and labour following CPWD / NBO norms.

Total payment for such extra items of work shall not exceed 10% of work order / agreement value/ approved deviation estimate value. Also total payment including extra items of work shall not exceed the work order / agreement / approved deviation estimate value.

5.6 PROVISIONS FOR DEALING WITH VARIATIONS IN RESPECT OF ABNORMALLY HIGH RATE AND ABNORMALLY LOW RATE ITEMS.

The abnormally high rate items are those whose quoted rates are more than 20% of the justified rates decided by the owner.

The abnormally low rate items are those whose quoted rates are less than 20% of the justified rates decided by the owner.

In case of Item Rate Tenders, the revision of rates for (i) abnormally high rate items and (ii) abnormally low rate items, shall become operative under the following circumstances:—

For increase in quantity of more than 25% in respect of works executed below plinth level and 10% in respect of works executed above plinth level.

Quantity variation beyond the limit mentioned above shall be dealt by arriving at new rate based on prevalent market rate of materials and labour analysed as per standard analysis of rate of CPWD/NBO. Payment of extra quantity over the permitted quantity as explained above would be made on the basis of the new analysed rate.

The variation in quantity of abnormally low rate items for item rate tenders shall not be permitted below 25% for the items below plinth level and below 10% for the items above plinth level of the agreement schedule quantity, but in exceptional cases with written consent of Engineer in Charge arising out of technical necessity.

The above provisions shall be applicable for item rate tenders only and not applicable for percentage rate tenders for works based on standard schedule of rates of the company.

For the purpose of operation, the following works shall be treated as works related to foundation, unless otherwise defined in the contract.

- a) *For Buildings: All works up to 1.2 metres above ground level or up to floor 1 level whichever is lower.*
- b) *For abutments, piers and well steining: All works up to 1.2m above the bed level.*
- c) *For retaining walls, wing walls, compound walls, chimneys, overhead reservoirs / tanks and other elevated structures: all works up to 1.2 metres above the ground level.*
- d) *For reservoirs / tanks (other than overhead reservoirs / tanks): All works up to 1.2 metres*

~~above the ground level.~~

~~e) For basement: all works up to 1.2m above ground level or up to floor 1 level whichever is lower.~~

~~For Roads, all items of excavation and filling including treatment of sub base~~

~~5.7 The time of completion of the originally contracted work shall be extended by the company in the event of any deviation resulting in additional cost over the awarded value, if requested by the contractor as follows:—~~

~~(i) In the proportion which the additional cost of the altered, additional or substituted work (in value) bears to the original tendered value plus.~~

~~(ii) 25% of the time calculated in (i) above or such further additional time as may be considered reasonable by the Engineer-in-Charge.~~

~~5.8 The company through its Engineer-in-Charge or his representative, on behalf of the company, shall have power to omit any part of the work in case of non-availability of a portion of the site or for any other reason and the contractor shall be bound to carry out the rest of the work in accordance with the instructions given by the Engineer-in-Charge. No claim from the Contractor shall be entertained/ accepted on these grounds.~~

~~5.9 In the event of any deviation being ordered which in the opinion of the contractor changes radically the original scope/nature of the contract, the contractor shall under no circumstances suspend the work, either original or altered or substituted, and the dispute/disagreement as to the nature of deviation and the rate/rates to be paid for such deviations shall be resolved separately with the company as per the procedures/ norms laid down hereafter.~~

6. Time for Completion of Contract, Extension thereof, Defaults and Compensation for Delay

Time is the essence of the contract and as such all works shall be completed within the time stipulated in the contract/ work order. The work shall, throughout the stipulated period of contract, be carried out with all due diligence on the part of the contractor.

Immediately after the contract is concluded i.e. LOA / Work Order is issued, the Engineer-in-Charge and the contractor shall agree upon a detailed time and progress chart prepared based on BAR CHART/ PERT CPM techniques on the basis of a construction schedule submitted by the contractor at the time of executing contract showing the order in which the work is proposed to be carried out within the time specified in the LOA /work order.

For the purpose of this detailed time and progress chart, the work shall be deemed to have commenced on the expiry of 10* (ten) days from the issue of Letter of Acceptance of Tender or 7(seven) days after handing over the site of work or handing over reasonable number of working drawings to the contractor or the period of mobilization allowed in the work order for starting the work in special circumstances, whichever is later. However, the Date of Commencement may be decided with mutual consent with the Contractor prior to the date as prescribed above.

* For Specialized Works/ High Value Works (above Rs. 5 crores), the period shall be 30 days.

6.1 If the contractor, without reasonable cause or valid reasons, commits default in commencing the work within the aforesaid time limit, the company shall, without

prejudice to any other right or remedy, be at liberty, by giving 15 day's notice in writing to the contractor to commence the work, failing which to forfeit the Earnest Money deposited by him and to rescind the Letter of Acceptance of Tender/Work Order and also to debar the contractor to take part in the future re-tender.

The Company may debar such defaulting Contractors from participating in future Tenders for a minimum period of 12(twelve) months.

6.2 If the contractor fails to complete the work and clear the site on or before the date of completion or extended date of completion, he shall without prejudice to any other right or remedy available under the law to the company on account of such breach, pay as compensation (Liquidated Damages):

i) @ half percent ($\frac{1}{2}$ %) of the contract amount/Revised Contract amount excluding GST whichever is less, per week or part of the week of delay.

OR

ii) $\frac{1}{2}$ % of the contract-value (excluding GST) of group of items/ revised completion value of group of items whichever is less, per week or part of the week of delay, for which a separate period of completion is originally given.

The aggregate of such compensation/ compensations shall not exceed:

i)10% (ten) percent of the total amount of the contract/ Revised contract amount excluding GST, whichever is less.

OR

ii) 10% of the contract-value (excluding GST) of group of items/ revised completion value of group of items whichever is less, for which a separate period of completion is originally given.

The amount of compensation may be adjusted or set off against any sum payable to the contractor under this or any other contract with the company.

The LD will be applicable on the price (excluding GST) as varied by the operation of the Price Variation Clause i.e. price variation amount (excluding GST) shall be added/ deducted to the contract price (excluding GST) for deriving the LD.

6.2.1 The company, if satisfied, that the works can be completed by the contractor within a reasonable time after the specified time of completion, may allow further extension of time at its discretion with or without the levy of L.D. In the event of extension granted being with L.D, the company will be entitled without prejudice to any other right or remedy available in that behalf, to recover from the contractor as agreed damages equivalent to half percent of the contract amount/ Revised Contract amount of the works excluding GST whichever is less for each week or part of the week subject to a ceiling as described at Cl.6.2.

6.2.2 The company, if not satisfied that the works can be completed by the contractor, and in the event of failure on the part of the contractor to complete work within further extension of time allowed as aforesaid, shall be entitled, without prejudice to any other right, or remedy available in that behalf, to rescind the contract.

6.2.3 The company, if not satisfied with the progress of the contract and in the event of failure of the contractor to recoup the delays in the mutually agreed time frame, shall be entitled to terminate the contract.

6.2.4 In the event of such termination of the contract as described in clauses 6.2.2 or 6.2.3 or both, the company, shall be entitled to impose penalty/LD as deliberated at Clause 10. Additionally, the contractor shall be debarred from participating in the future tenders for a minimum period of 12 months.

In the event of recovery of any claim towards LD Charges, Penalty, fee, fine or any other charges from the supplier/vendor, the same will be recovered excluding GST and the amount shall be adjusted with the payment to be made to the supplier/vendor against their bill/invoice or any other dues.

6.3 The company may at its sole discretion, waive the payment of compensation on request received from the contractor indicating valid and acceptable reasons if the entire work is completed within the date as specified in the contract/work order or as validly extended date without stipulating any compensation for delay.

6.4 Extension of Contract Time for completion

- A. **Force Majeure (FM):** Conditions beyond control of either parties like war, hostility, acts of public enemy, civil commotion, sabotage, serious loss or damage by fire, explosions, epidemics, strikes, lockouts or acts of God come under the legal concept of Force Majeure (FM).

Delays in performance of contractual obligations under influence of FM conditions are condonable by the other party without any right to termination or damages, provided, notice of the happening of any such event is given by the affected party to the other within 30 (thirty) days from the date of occurrence duly certified by the local chamber of commerce or statutory authorities, the beginning and end of FM occurrence and cessation of such Force Majeure condition. Works under the contract shall be resumed as soon as practicable after such event has come to an end or ceased to exist.

For delays arising out of Force Majeure, the bidder / contractor will not claim extension in completion date for a period exceeding the period of delay attributable to the clauses of Force Majeure and neither company shall be liable to pay nor bidder / contractor shall be liable to claim extra cost (like increase in rates, remobilization advance, idle charges for labour and materials etc.) provided it is mutually established that Force majeure conditions did actually exist.

B. Delays in Execution

A work may be completed ahead of schedule or delayed due to unforeseen fortuitous circumstances, extra effort or developments beyond the control of CIL/Subsidiary or the tenderer and it is sometimes difficult to apportion credit or responsibility. The contractor may experience delay or disruption due to his own ac-

tions or inaction, those of his sub-contractor or other contractors, those of CIL/Subsidiary or the engineer, or other causes. Such delays expose the non-performing party to various sanctions under the contract. These sanctions include extension of time, damages or default termination of the contract. While examining the request of the contractor for extension of time, the engineer shall consider all circumstances and categorise the delays as follows:

- a) Excusable delays - Force Majeure (FM), that is, acts of God, abnormal weather, floods, and so on, applies;
 - b) Compensable delays – or Compensation Events, which put full burden of responsibility on CIL/Subsidiary; and
 - c) Inexcusable delay (contractor's own faults), which puts the full burden of responsibility on the contractor.
 - d) Concurrent delays - when two or more events responsible for delay overlap each other. The delays may be attributable to CIL/Subsidiary or the contractor or none, and fall in above categories. The eligibility for extension of time (EOT) should be determined by plotting each contributing concurrent delay on the critical path. CIL/Subsidiary should see that the concurrent delays do not result in unnecessary extra extension of time.
- C. Once the delay is categorised, it should then be determined not only whether the contractor is eligible for time extension but also whether sanctions, such as Liquidated Damage (LD) or default termination, can be imposed on the contractor.
- D. The time for completion of the work will be specified in the contract and it is understood that the completion of work within the time specified is an essential part of this contract. While ascertaining the reasons for delay beyond the control of the contractor, the following delays shall be considered as "Hinderance":-
- a. Excusable delays
 - b. Compensable delays
 - c. Portion of Concurrent delays to be decided judiciously by the EIC.
- E. More precisely, if any delay in the completion of the work is likely to be caused by any of the following reasons, then the contractor immediately upon the occurrence of such delay shall give notice in writing to the Engineer-in-Charge and he shall be allowed a reasonable extension of time for completion in respect of delay caused by any of the below-mentioned circumstances-
- a) Force Majeure as defined at 6.4(A);
 - b) Abnormally bad weather.
 - c) Non-availability of stores which are the responsibility of the company to supply as per contract.
 - d) Non-availability of working drawings in time, which are to be made available by the company as per contract during progress of the work.
 - e) Delay on the part of the contractors or tradesmen engaged by the company not forming part of the contract, holding up further progress of the work.

- f) Non-availability or breakdown of tools and plant to be made available or made available by the company.
- g) The execution of any modified or additional items of work or excess quantity of work.
- h) Any other causes which, at the sole discretion of the company, is beyond the control of the contractor
- i) Delay caused by any written instruction of the Engineer in Charge.
- j) Any circumstances which are wholly beyond the control of the contractor and unavoidable
- k) Increase in the overall value of work. The time of completion of the work shall, in the event of any deviation resulting in additional cost over the tendered value sum being ordered, be extended, if requested by the contractor as follows:
 - i. In the proportion which the additional cost of the altered, additional or substituted work, bears to the original tendered value plus.
 - ii. 25% of the time calculated in i) above or such further additional time as may be considered reasonable by the Engineer -in -Charge.
- l) Portion of Concurrent delays as decided judiciously by the EIC

F. **HINDERANCE REGISTER** shall be maintained by both department and the contractor at site to record the various hindrances encountered during the course of execution.

Hindrance register will be signed by both the parties. The contractor may also record his observations in the Hindrance Register. In case the contractor has a different opinion for hindrance and a dispute arises then the matter would be referred to the EIC and or the next higher authority whose decision would be final & binding on the contractor & the decision to be communicated within 15 days.

Interim Extension of completion time may be granted by Tender Accepting Authority limited to GM(ExcV)/HoD for HQ works and Area GM for area works as per provision of clause 6.4.1 below, based on the recommendation of the Engineer-in-Charge of the work during the course of execution of work reserving the right to impose/waive the clause relating to compensation for delay at the time of granting final extension of time depending upon the merit of the case. Final Extension of completion time is to be granted by Tender Approving Authority limited to CMD of CIL/ Subsidiary

6.4.1 General Principles for Granting Extension of Time

- i) At the time of issuing notice inviting tenders for a particular work the Engineer-in-Charge should specify the time allowed for completion of the work consistent with the magnitude and urgency of the work.
- ii) The time allowed for carrying out the work as entered in the contract shall be strictly observed by the contractor and shall be reckoned from the Date of Commencement of the work as given to the contractor.

iii) The work shall throughout the stipulated period of the contract be proceeded with all due diligence (time being deemed to be the essence of the contract) on the part of the contractor.

iv) To ensure good progress of work during the execution, the contractor shall meticulously follow the preset time and progress chart and in the event of slippages in one segment, all efforts will be made to liquidate the slippages in the next stages.

v) If the contractor shall desire an extension of time for completion of work on the grounds of his having been unavoidably hindered in its execution or on any other grounds as mentioned above shall make application to Engineer-In-Charge for extension of contract within a reasonable period prior to expiry of Contract Period (Preferably not later than 15 days prior to expiry of Contract Period). Engineer-In-Charge shall process the proposal based on the merit of the case for obtaining approval of Competent Authority. Such extension shall be communicated to the contractor in writing by the company through Engineer-in-Charge before the expiry of Contract Period.

vi) Engineer-in-Charge shall process extension of time for the completion of the work if the following conditions are satisfied:

a) The contractor must apply to the Engineer-in-Charge in writing for extension of time.

b) Such application must state the grounds which hindered the contractor in the execution of the work within the stipulated time.

c) Such application must be made within a reasonable period prior to expiry of Contract Period (Preferably not later than 15 days prior to expiry of Contract Period).

d) The Engineer-in-Charge must be of the opinion that the grounds shown for the extension of time are reasonable.

Vii) Deleted

viii) The opinion of the Engineer-in-Charge, whether the grounds shown for the extension of time are or not reasonable, is final. If the Engineer-in-Charge is of the opinion that the grounds shown by the contractor are not reasonable and declines to process the extension of time, the contractor may approach concerned SO(Excv) /GM (Excv) /Director (As the case may be) whose opinion shall be final and binding on all concerned.

ix) All interim extensions of time shall be granted by Tender Accepting Authority limited to GM(Excv)/HoD for HQ works and Area GM for area works and all final extension of time shall be granted by Tender Accepting Authority limited to Chairman/ CMD of CIL/ Subsidiary.

Effort should be made to complete the work within the original contract period or extended period.

x) In case the contractor does not apply for grant of extension of time before the expiry of contract period and the department wants the contractor to continue with the work beyond the stipulated date of completion, the Engineer-in-Charge can process proposal for extension of time even in the absence of application from the contractor as per the following guidelines :

a) Whenever any hindrance comes to the notice of the In Charge of the work, he should at once make a note of such hindrance in the register kept at site. He should also make a report to EIC of the occurrence of such hindrance.

b) The proposal for extension of time should be processed by EIC for obtaining the approval of Competent Authority (Ref Cl (ix) above . This should be processed preferably 15 days prior to the expiry of Contract Period.

c) If the orders of the higher authority are not received in time, he should extend the contract before the stipulated date actually expires so that the contract might remain in force but while communicating this extension of time, he must inform the contractor that this was without prejudice to Company's right to levy compensation under relevant clause of the agreement. Such extension of time given by EIC shall be considered as fait-accompli in future.

xi) The period during which the contract remains valid is a matter of agreement and if the period originally set for the completion of the work comes to an end nothing short of agreement of the party can extend the subsistence and validity of the contract.

xii) When the period fixed for the completion of the contract is about to expire, the question of extension of the contract may be considered at the instance of the contractor or the Department or of both.

The extension, in order to be binding, will have to be by parties' agreement, express or implied.

It therefore, follows that if the extension of time is issued /granted by the Engineer-in-Charge suo-moto as per provisions of Contract Agreement as per Cl 6.4.1(x) and such extension of time is accepted by the contractor, either expressly or implied by his actions before and subsequent to the date of completion, the extension of time granted by the Engineer-in-Charge is valid.

xiii) It is, therefore, necessary that the Engineer-in-Charge grants extension of time as per provisions of the contract even when the contractor does not apply for extension of time in order to keep the contract alive. If the contractor refuses to act upon the extension so granted by Engineer-in-Charge, it will attract the provisions of appropriate clauses of the agreement.

The contractor shall however use his best efforts to prevent or make good the delay by putting his endeavors constantly as may be reasonably required of him to the satisfaction of the Engineer-in-Charge.

7. Material Supply & other facilities:

The contractor shall at his own expense, provide all materials required for the work, unless otherwise specified, and the rates quoted by the contractor shall be for finished work inclusive of all materials required for completion of the work as specified in the contract.

7.1 All materials, tools, PPE and plants brought to site by the contractor including the materials supplied by the company shall be deemed to be held in lien by the company and the contractor shall not have the right to remove the same from the site, without the written permission of the Engineer-in-Charge. The company shall not however be liable for any loss, theft or damage due to fire or other cause during this period of lien, the responsibility for which shall lie entirely on the contractor.

7.2 The contractor shall bear the cost of loading, transportation to site, unloading, storing under cover as required etc. as may be necessary for the use and keeping the materials in good condition.

7.3 All charges on account of GST or any other applicable taxes, duties or levies on materials obtained for the works from any source (excluding materials supplied by the company) shall be borne by the contractor.

8. Quality Assurance - Materials and Workmanship

The contractor shall carry out and complete the work in every respect in accordance with the contract and shall ensure that the work conforms strictly to the drawings / specifications, if any and instructions of the Engineer-in-Charge. The Engineer-in-Charge may issue, from time to time, further drawings/ detailed instructions/ directions in writing to the contractor. All such drawings/ instructions/directions shall be consistent with the contract documents and should be reasonably inferable there from, along with clarifications/ explanations.

8.1 For Quality Assurances of all the repairing works the norms/ guidelines laid down by the company herein and elsewhere will form part of the contract for the purpose of quality of works.

8.2 The contractor shall be responsible for correct and complete execution of the work in a workman like manner with the materials as per specification. All work under execution in pursuance of the contract shall be open to inspection and supervision by the Engineer-in-Charge or by his authorized representative or any other official of higher rank or any other person authorized by the company in his behalf & the contractor shall allow the same.

8.3 All materials to be provided by the contractor shall be in conformity with the specifications as per the contract and the contractor shall furnish proof, if so required by the Engineer-in-Charge to his satisfaction that the materials do so comply.

8.4 The company, through the Engineer-in-Charge, shall have full powers to reject any materials or work due to a defect therein for not conforming to the required specification, or for materials not being of the required quality and standard or for reasons of poor workmanship or for not being in accordance with the sample approved by him. The contractor shall forthwith remedy the defect/replace the materials at his expense and no further work shall be done pending such rectification/replacement of materials, if so instructed by the Engineer-in-Charge.

In case of default on the part of the contractor, the Engineer-in-Charge shall be at liberty to procure the proper materials for replacement and/or to carry out the rectifications in any manner considered advisable under the circumstances and the entire cost & delay for such procurement/rectification shall be borne by the contractor.

8.5 The Engineer-in-Charge shall be entitled to have tests carried out for any materials, according to the standard practice followed for such tests, other than those for which satisfactory proof has already been furnished by the contractor who shall provide at his expense all facilities which the Engineer-in-Charge may require for the purpose. All such expenses born by the contractor are not to be paid separately by the employer and shall be assumed covered in accepted prices.

The cost of any other tests, if so required by the Engineer-in-Charge, shall be borne by the company. However if the test shows the workmanship or materials not to be in accordance with the provision of the contract or the instruction of Engineer-in-Charge the cost shall be borne by the contractor.

8.6 Access to the works: The Engineer-in-charge and any person authorized by the company shall at all times have access to the works and to all workshops and places where work is being prepared or from where materials, manufactured articles are being obtained for the works and the contractor shall afford every facility for and every assistance in or in obtaining the right to such access.

8.7 Inspection of works:

- i) No work shall be covered up or put out of view without the approval of the Engineer-in-charge or the Engineer-in-charge's representative or any other officer nominated by the company for the purpose and the contractor shall afford full opportunity for the EIC or EIC's representative or any other officer nominated by the company for the purpose to examine and measure any work which is about to be covered up or put out of view and to examine.
- ii) The contractor shall uncover any part or parts of the works or making openings in or

through the same as the Engineer-in-Charge may from time to time direct and shall re-instate and make good such part or parts to the satisfaction of Engineer-in-charge.

If any such part or parts have been covered up or put out of view after compliance with the requirement of sub-clause above and are found to be executed in accordance with the contract, the expenses of uncovering, making openings in or through and making good the same shall be borne by the Employer, but in any other cases all costs shall be borne by the contractor.

8.8 Removal of Improper Work and Materials:

i) The Engineer-in-charge shall during the progress of the works have power to order in writing from time to time:

a) The removal from the site, of any materials which in the opinion of Engineer-in-charge, are not in accordance with the contract/ work order/ approved sample.

b) The substitution with improper and unsuitable materials.

c) The removal and proper re-execution, notwithstanding any previous test thereof or interim payment there from, of any work which in respect of materials or workmanship is not in accordance with the contract.

ii) In case of default on the part of the contractor in carrying out such order, the Engineer-in-charge shall be entitled to employ and pay other agency to carry out the same and all expenses consequent thereon shall be recoverable from the contractor or may be deducted from any amount due or which may become due to the contractor.

8.9 Final Inspection of Work: The Engineer-in-charge and any other officer nominated by the company for the purpose shall make final inspection of all work included in the contract/work order, or any portion thereof, or any completed part of the work of the contract, as soon as practicable after notification by the contractor that the work is completed and ready for acceptance.

If the work is not acceptable to the Engineer-in-charge at the time of such inspection, he shall inform the contractor in writing as to the particular defects to be remedied before final acceptance can be made. (Place of inspection prevail the condition of concerned work-order.)

8.10 Defects appearing after acceptance:

Any defects which may appear within the defect liability period and arising, in the opinion of the Engineer-in-charge, from lack of conformance with the drawings and specifications, shall, if so required by the Engineer-in-charge in writing, be remedied by the contractor at his own cost within the time stipulated by the Engineer-in-charge. If the contractor fails to comply, the Engineer-in-charge may employ other persons to remedy the defects and recover the cost thereof from the dues of the contractor.

8.11 Storage of Materials: Materials shall be so stored as to ensure the preservation of the quality and fitness for the work.

8.11 Defective Materials: All materials not conforming to the requirements of the specifications shall be considered as defective, and all such materials, whether in place or not shall be rejected. They shall be removed immediately by the contractor at his expenses and replaced with acceptable material.

9. Measurement and Payments

Except where any general or detailed description of the work in the Bill of Quantities or specifications of the contract/ work order provides otherwise, measurement of work done shall be taken in accordance with the relevant standard method of measurement published by the Bureau of Indian Standards (BIS) and if not covered by the above, other relevant Standards/practices shall be followed as per instructions of the Engineer-in-Charge.

9.1 All items of work carried out by the contractor in accordance with the provision of the contract having a financial value shall be entered in the Measurement Book/log book as prescribed by the company so that a complete record of the measurements/inspection is available for all the works executed under the contract and the value of the work executed can be ascertained and determined there from. Measurements/inspection of completed work / portion of completed work shall be recorded only in the Measurement Books/log books.

9.2 Measurement/inspection shall be taken jointly by the Engineer-in-Charge or his authorized representative and by the contractor or his authorized representative.

9.3 Before taking measurements/inspection of any work, the Engineer-in-Charge or the person deputed by him for the purpose shall intimate the contractor to attend or to send his representative to attend the measurement. Every measurements/inspection thus taken shall be signed and dated by both the parties on the site on completion of the measurement. If the contractor objects to any measurements/inspection, a note to that effect shall be made in the Measurement Book / Log Book and signed and dated by both the parties.

9.4 The measurement/inspection of the portion of work/items of work objected to, shall be re-measured/re-inspected by the Engineer-in-Charge himself or the authority nominated by the company for the purpose in the presence of the contractor or his authorized representative **and recorded in the log book which Shall be signed and dated by both parties.** Measurement/inspection so recorded shall be final and binding upon the contractor and no claim whatsoever shall thereafter be entertained.

In case the contractor or his authorized representative does not attend to the joint measurements/inspection at the prefixed date and time after due notice, the measurements taken by the Engineer-in-Charge or his representative shall be final and binding on the contractor.

9.5 Payments: The running on account payments may be made once in a month or at intervals stipulated in the work order/ contract agreement.

9.5.1 Running on account bill/bills for the work executed/ materials supplied in accordance with the work order/contract as described herein before and processed for payments.

9.5.2 Payment of on account bill shall be made on the Engineer-in-Charge's certifying the sum to which the contractor is considered entitled by way of interim payment (if any) for the following:

- a) The work executed as covered by the bill/bills after deducting the amount already paid, the security deposit and such other amounts as may be deductible or recoverable in terms of the work order/ contract (as per work order).
- b) On the Engineer-in-Charge's certificate of completion in respect of the work covered by the contract / work order final work certified by the Engineer In Charge

or his representative.

- 9.5.3** The company reserve the right to recover/enforce recovery of any overpayments detected after the payment as a result of post payment audit or technical examination or by any other means, notwithstanding the fact that the amount of disputed claims, if any, of the contractor exceeds the amount of such overpayment and irrespective of the facts whether such disputed claims of the contractor are the subject matter of arbitration or not.

The amount of such overpayments shall be recovered from subsequent bills under the contract, failing that from contractor's claim under any other contract with the company or from the contractor's security deposit or the contractor shall pay the amount of over payment on demand. In case of contractor's non-payment on such demand, the same should be realised from the contractor's dues, if any, with Coal India Limited or any of its subsidiaries.

- 9.5.5** The contractors are required to execute all works satisfactorily and according to the specifications laid down in the contract/ work order. If certain items of work, executed by the contractor, are below specifications, the contractor should re-do them according to the specifications and instructions of EIC and if the contractor fails to rectify the defect within the time and in the manner specified by the EIC, the work shall be got re-done or rectified by the department at the risk and cost of the contractor. Engineer-in-Charge may accept such work of below specifications provided the department, if satisfied with the quality and the strength/ structural safety of such works. In that case Engineer-in-Charge shall make such deductions for the difference in value, as in his opinion is reasonable and is approved by the accepting authority of the company i.e. GM/SO(Excavation) of the company in this case or any other officer nominated by GM/SO(Excavation) for the purpose.

9.5.6 Payment Stage: The payment stage involved will be as under,

- i. Signature of Section In-charge (Concerned Section) with appropriate check measurements in MB's/ log book and the bill form.
- ii. Signature of Engineer-in-Charge as per definition as at clause 1(xvii) of the General Terms and Conditions, as a token of acceptance for payment of the bill. The EIC may sign in the abstract of the bill in the MB/log book & the bill form. In between stage i) and ii) accountable checking may be made by the concerned Accounts Officer/ Accountant, if MB is prepared.

9.6 No interest shall be payable on the amounts withheld, under the terms of the Contract Agreement/Work-order.

10 Termination, Cancellation, Suspension and Foreclosure of Contract

The company shall, in addition to other remedial steps to be taken as provided in the conditions of contract be entitled to cancel the contract in full or in part, and whether the date of completion has or has not elapsed, by a two weeks show cause notice in writing if the contractor:-

- a) makes default in proceeding with the works with due diligence and continues to do so

even after a notice in writing from the Engineer-in-Charge, then on the expiry of the period as specified in the notice

Or

b) commits default/breach in complying with any of the terms and conditions of the contract and does not remedy it or fails to take effective steps for the remedy to the satisfaction of the Engineer-in-Charge, then on the expiry of the period as may be specified by the Engineer-in-Charge in a notice in writing.

Or

c) obtains a contract with the company as a result of ring tendering or other non-bonafide methods of competitive tendering

Or

d) shall offer or give or agree to give any person in the service of the company or to any other person on his behalf any gift or consideration of any kind as an inducement or reward for act/acts of favour in relation to the obtaining or execution of this or any other contract for his company.

Or

e) fails to complete the work or items of work with individual dates of completion, on or before the date/dates of completion or as extended by the company, then on the expiry of the period as may be specified by the Engineer-in-Charge in a notice in writing.

Or

f) transfers, sublets, assigns the entire work or any portion thereof without the prior approval in writing from the Engineer-in-Charge. The Engineer-in-Charge may by giving a written notice, cancel the whole contract or portion of it in default.

Or

g) breach of the prohibition against sub-contracting

Or

h) Committed fraud

However, the contractor shall continue to fulfil the contract to the extent not terminated.

10.1The contract shall also stand terminated under any of the following circumstances:

a) If the contractor being an individual in the case of proprietary concern or in the case of a partnership firm any of its partners is declared insolvent under the provisions of Insolvency Act for the time being in force, or makes any conveyance or assignment of his effects or composition or arrangement for the benefit of his creditors amounting to proceedings for liquidation or composition under any Insolvency Act.

b) In the case of the contractor being a company, its affairs are under liquidation either by a resolution passed by the contractors company or by an order of court, not being a voluntary liquidation proceedings for the purpose of amalgamation or reorganization, or a receiver or manager is appointed by the court on the application by the debenture holders of the contractor's company, if any.

c) If the contractor shall suffer an execution being levied on his/their goods, estates and allow it to be continued for a period of 21 (twenty-one) days.

d) On the death of the contractor being a proprietary concern or of any of the partners in the case of a partnership concern and the company is not satisfied that the legal representative of the deceased proprietor or the other surviving partners of the partnership

concern are capable of carrying out and completing the contract. The decision of the company in this respect shall be final and binding which is to be intimated in writing to the legal representative or to the partnership concern.

10.2 On cancellation of the contract (except action as per clause 6.1 of GCC) or on termination of the contract, the Engineer-in-charge shall have powers:

a. To take possession of the site, any materials, constructional plant, equipment, stores etc. thereon and carry out balance work through any means or through any other agency.

b. To give the contractor or his representative of the work 7 (seven) days notice in writing for taking final measurement for the works executed till the date of cancellation or termination of the contract. The Engineer-in-Charge shall fix the time for taking such final measurement and intimate the contractor in writing. The final measurement shall be carried out at the said appointed time notwithstanding whether the contractor is present or not. Any claim as regards measurement which the contractor is to make shall be made in writing within 7 (seven) days of taking final measurement by Engineer-In-charge as aforesaid and if no such claim is received, the contractor shall be deemed to have waived all claims regarding above measurements and any claim made thereafter shall not be entertained.

c. After giving notice to the contractor to measure up the work of the contractor and to take such whole or the balance or part thereof, as shall be unexecuted out of his hands and to give it to another contractor or take up departmentally, to complete the work. The contractor whose contract is terminated shall not be allowed to participate in future bidding for period of minimum twelve months.

In such an event, the contractor shall be liable for loss/damage suffered by the employer because of action under this clause and to compensate for this loss or damage, the employer shall be entitled to recover higher of the following:

i) Forfeiture of security deposit comprising of performance guarantee and retention money at the disposal of the employer.

Or

ii) 20% of value of incomplete work excluding GST. The value of the incomplete work shall be calculated for the items and quantities remaining incomplete (as per provision of agreement) at the agreement rates (excluding GST) including price variation (excluding GST) as applicable on the date, when notice in writing for termination of work was issued to the contractor.

The amount to be recovered from the contractor as determined above, shall, without prejudice to any other right or remedy available to the employer as per law or as per agreement, will be recovered from any money due to the contractor on any account or under any other contract and in the event of any shortfall, the contractor shall be liable to pay the same within 30 days. In case of failure to pay the same the amount shall be debt payable.

In the event of above course being adopted by the Engineer-in-charge, the contractor shall have no claim to compensation for any loss sustained by him by

reasons of his having purchased materials, equipment or entered into agreement or made advances on any account or with a view to the execution of work or performance of the contract. And in case action is taken under any of provision aforesaid, the contractor shall not be entitled to recover or to be paid any sum for any work thereof or actually performed under this contract unless and until the engineer-in-charge has certified in writing the performance of such work and value payable in respect thereof and he shall only be entitled to be paid the value so certified.

The need for determination of the amount of recovery of any extra cost/expenditure or of any loss/damage suffered by the company shall not however arise in the case of termination of the contract for death/demise of the contractor as stated in 10.1(d).

10.3 Suspension of Work:

Suspension of work – The Company shall have power to suspend the work. The contractor shall on receipt of the order in writing of Engineer-in-charge (whose decision shall be final and binding on the contractor), suspend the progress of work or any part thereof for such time in such manner as the Engineer-in-Charge may consider necessary so as not to cause any damage, or endanger the safety thereof for any of the following reasons:

- a) on account of any default on the part of the contractor, or
- b) for proper execution of the works, or part thereof, for reasons other than the default of the contractor or,
- c) for safety of the works, or part thereof.

The contractor shall, during such suspension properly protect and ensure the works to the extent necessary and carry out the instruction of the Engineer-in-charge. If the suspension is ordered for reasons (b) & (c), the contractor shall be entitled to an extension of time equal to the period of every such suspension plus 25%. This shall also be applicable for completion of the item or group of items of the work for which a separate period of completion as specified in the contract and of which the suspended work forms a part.

The contractor shall carry out the instructions given in this respect by the Engineer-In Charge & if such suspension exceeds 45 (forty five) days, the contractor will be compensated on mutually agreed terms.

10.4 Foreclosure of contract:

If at any time after acceptance of the tender the company decides to abandon or reduce the scope of work for any reason whatsoever the company, through its Engineer-in-Charge, shall give notice in writing to that effect to the contractor and contractor shall act accordingly in the matter. In the event of abandonment, the contractor shall have no claim to any payment of compensation or otherwise whatsoever, other than those mentioned below: -

- a) to pay the contractor at the contract rates full amount for works executed and measured at site up to the date of such abandonment.
- b) to pay for the materials brought to site or to be delivered at site, which the contractor is legally liable to pay, for the purpose of consumption in works carried out or were to be carried out but for the foreclosure, including the cost of purchase and transportation and cost of delivery of such materials. The materials to be taken over by the company should be in good condition and the company may allow at its dis-

cretion the contractor to retain the materials in full or in part if so desired by him and to be transported by the contractor from site to his place at his own cost with due permission of the EIC.

c) to take back the materials issued by the company but remaining unused, if any, in the work on the date of abandonment/reduction in the work, at the original issue price less allowance for any deterioration or damage caused while in custody of the contractor.

d) to pay for the transportation of tools and plants of the contractor from site to contractor's place or to any other destination, whichever is less.

10.4.01 The contractor shall, if required by the Engineer-in-Charge, furnish to him books of accounts, papers, relevant documents as may be necessary to enable the Engineer-in-Charge to assess the amounts payable in terms of clauses 10.4(b) & (d) of the contract. The contractor shall not have any claim for compensation for abandonment of the work, other than those as specified above.

11. Carrying out Part Work at Risk & Cost of Contractor.

If the progress of the work or of any portion of the work is unsatisfactory, the Engineer-in-Charge, after giving the contractor 15 days' notice in writing, without cancelling or terminating the contract, shall be entitled to employ another Agency for executing the job or to carry out the work departmentally or contractually through tendering / limited tendering process, either wholly or partly, debiting the contractor with cost involved in engaging another Agency or with the cost of labour and the prices of materials, as the case may be. The certificate to be issued by the Engineer-in-Charge for the cost of the work so done shall be final and conclusive and the extra cost, if any, shall be borne by the contractor. However, when this clause is invoked, penalty will not be applicable other than on account of delayed completion.

The value of the work taken away shall be calculated for the items and quantities taken away at the agreement rates including price variation as applicable on the date, when notice in writing for taking away part work was issued to the contractor. The contractor, from whom part work is being taken out, shall not be allowed to participate in the tendering process if any.

If the expenses incurred by the department is less than the amount payable to the contractor at his agreement rates, the difference shall not be payable to the contractor.

In the event of above course being adopted by the Engineer-in-Charge, the contractor shall have no claim to compensation for any loss sustained by him by reasons of his having purchased or procured any materials or entered into any engagements or made any advance on any account or with a view to the execution of the work or the performance of the contract.

Note: In this case, the provisions like SPLT (Refer Clause No. 4.01.11 of Part I of MCEW) may be resorted to by CIL/ Subsidiary.

12. Additional Responsibilities of the Contractor(s)

The cost on account of the "Additional Responsibilities of the Contractors" under this clause is deemed to be included in the tendered rates.

- i) The company reserves the rights to let other contractors also work in connection

with the Project and the contractor/contractors shall co-operate in the works for the introduction and stores and materials and execution of his /their works.

- ii) Precautions shall be exercised at all times by the contractor(s) for the protection of persons (including employees) and property. The safety required or recommended by all applicable laws, the contractor(s) shall observe codes, statutes and regulations. In case of accidents, the contractor(s) shall be responsible for compliance with all the requirements imposed by the Workmen's Compensation Act or any other similar laws in force and the contractor shall indemnify the company against any claim on this account.

All scaffoldings, ladders and such other structures which the workmen are likely to use shall be examined by the Engineer-in-Charge or his authorized representative whenever they want and the structure must be strong, durable, and safe and of such design as required by Engineer-in-Charge.

In no case any structure condemned by the Engineer-in-Charge or his authorized representatives shall be kept on the work and such structure must be pulled down within three hours of such condemnation and any certificate or instructions, however, shall in no way absolve the contractor/contractors from his/their responsibility, as an employer, as the company shall in no way be responsible for any claim.

The contractor / contractors shall at all times exercises reasonable precautions for the safety of employees in the performance of his/their contract and shall comply with all applicable provisions of the safety laws drawn up by the State Govt. or Central Govt. or Municipalities and other authorities in India. The contractor/contractors shall comply with the provision of the safety handbook as approved and amended from time to time by the Government of India.

- iii) The contractor / contractors shall familiarize themselves with and be governed by all laws and rules of India and Local statutes and orders and regulations applicable to his/ their work.
- iv) The contractor shall maintain all records as per the provision made in the various statutes including Contract Labour (Regulation & Abolition) Act, 1970 and the Contract Labour (Regulation & Abolition) Central Rules, 1971, Minimum Wages Act, Workmen Compensation Act etc. and latest amendment thereof. Such records maintained by the contractor shall be opened for inspection by the Engineer-in-Charge or by the nominated representative of the Principal Employer.
- v) The contractor/ contractors shall provide facilities for the sanitary necessities of all persons employed on the work shall be constructed and maintained in the number, manner and place approved or ordered by the Engineer-in-Charge. The contractor/ contractors shall vigorously prohibit committing of nuisance at any other place. Cost of all works under this item shall be covered by the contractor/contractor's tendered rates.
- vi) The contractor/contractors shall furnish to the Engineer-in-Charge or his authorized representative with work reports from time to time regarding the contractor / contractors organization and the progress made by him / them in the execution of the work as per the contract.

- vii) All duties, taxes (excluding Goods and Services Tax and GST Compensation Cess (If applicable) only) and other levies, royalty, building and construction workers cess (as applicable in States), whether local, municipal, provincial or central pertaining to the contract payable by the bidder/Contractor under the Contract (during the entire period of contract), or for any other cause as applicable on the last date of submission of Bid, shall be included in the rates, prices and the total Bid Price submitted by the Bidder. Applicable GST, if any, either payable by bidder or by company under reverse charge mechanism shall be computed by system in BOQ sheet as per predefined logic.

All investments, operating expenses, incidentals, overheads, lifts, carriages, tools and plants etc. as may be attendant upon execution and completion of works shall also be included in the rates, prices and total Bid price submitted by the bidder.

However, such duties, taxes, levies etc. which is notified after the last date of submission of Bid and/or any increase over the rate existing on the last date of submission of Bid shall be reimbursed by the company on production of documentary evidence in support of payment actually made to the concerned authorities.

Similarly if there is any decrease in such duties, taxes and levies the same shall become recoverable from the contractor. The details of such duties, taxes and other levies along with rates shall be declared by the bidder.

The item wise rate quoted by bidder shall be inclusive of all taxes, duties & levies but excluding GST & GST Compensation Cess, if applicable. The payment of GST and GST Compensation Cess by service availer (i.e. CIL/Subsidiary) to bidder/contractor (if GST payable by bidder/contractor) would be made only on the latter submitting a Bill/invoice in accordance with the provision of relevant GST Act and the rules made thereunder and after online filing of valid return on GST portal. Payment of GST & GST Compensation Cess is responsibility of contractor.

Further, any GST credit note required to be issued by the bidder / contractor under the GST provisions should be issued within the time limit prescribed under the GST law.

However, in case bidder/contractor is GST unregistered bidder/dealer or GST registered under composition scheme in compliance with GST rules, the bidder/dealer shall not charge any GST and/or GST Compensation Cess on the bill/invoice. In case of unregistered dealer/bidder, GST, if applicable will be deposited by CIL/Subsidiary directly to concerned authorities in terms with GST provisions.

Input tax credit is to be availed by CIL/Subsidiary as per rule.

If CIL/Subsidiary fails to claim Input Tax Credit(ITC) on eligible Inputs, input services and Capital Goods or the ITC claimed is disallowed due to failure on the part of supplier/vendor of goods and services in incorporating the tax invoice issued to CIL/Subsidiary in its relevant returns under GST, payment of CGST & SGST or IGST, GST (Compensation to State) Cess shown in tax invoice to the tax authorities, issue of proper tax invoice or any other reason whatsoever, the applicable taxes &cess paid based on such Tax invoice shall be recovered from the current bills or any other dues

of the supplier/vendor along with interest and penalty, if any.

The rates and prices quoted by the Bidder shall be fixed for the duration of the contract and shall not be subject to variations on any account except to the extent variations allowed as per the conditions of the contract of the bidding document.

The company reserves the right to deduct/ withhold any amount towards taxes, levies, etc. and to deal with such amount in terms of the provisions of the Statute or in terms of the direction of any statutory authority and the company shall only provide with certificate towards such deduction and shall not be responsible for any reason whatsoever.

In case of collection of minor minerals in area (both virgin and non-virgin), acquired by the Company under the Coal Act, the contractor will have to produce a royalty clearance certificate from the District Authorities before full and final payment.

Note: During the execution of the contract if the GST status of the bidder changes, then the payment of GST, if any, to the contractor will be made as per the GST status declared by the bidder during tender stage based on which cost to company has been ascertained or at actuals, whichever is lower.

- viii) The contractor / contractors shall make his / their own arrangement for all materials, tools, staff and labourer required for the contract, which shall include cost of lead, lift, loading, unloading, railway freight, recruiting expenses and any other charges for the completion of the work to entire satisfaction of the company.
- ix) The contractor / contractors shall make their own arrangement for carriage of all materials to the work site at his/their own cost or as mentioned in the work order.
- x) The work shall not be sublet to any other party, unless approved by Engineer-in-Charge, in writing. Prior permission is required to be taken from the owner for engagement of sub-contractor in part work/ piece rated work.
- xi) The contractor / contractors shall not pay less than the minimum wages to the labourer engaged by him/them as per Minimum Wages Act or such other legislation or award of the minimum wage fixed by the respective State Govt. or Central Govt. as may be in force. The contractor / contractors shall make necessary payments of the provident fund for the workmen employed by him for the work as per the laws prevailing under provisions of CMPF and allied scheme and Miscellaneous Provisions Act, 1948 or Employees Provident Fund and Miscellaneous Provisions Act 1952 as the case may be.
- xii) All accounts shall be maintained properly and the company shall have the right of access and inspection of all such books of accounts etc., relating to payment of labourer including payment of provident fund considered necessary and the company may arrange for witnessing the payment to the labourer by its representatives.
- xiii) The contractor shall in additions to any indemnity provided by the relevant clauses of the law, indemnify and keep indemnified for the following:

- a) The company or any agent or employee of the company against any action, claim or proceeding relating to infringement or use of any patent or design right and shall pay any royalties or other charges which may be payable in respect of any article or material included in the contract.
- However, the amount so paid shall be reimbursed by the company in the event such infringement has taken place in complying with the specific directions issued by the company or the use of such article or material was the result of any drawing and/or specifications issued by the company after submission of tender by the contractor. The contractor must notify immediately after any claim being made or any action brought against the company, or any agent or employee of company in respect of any such matter.
- b) The company against all claims, damages or compensation under the provisions of payment of Wages Act, 1938, Minimum Wages Act, 1948, Employer's Liability Act, 1938, The Workmen's Compensation Act, 1923, Industrial Dispute Act, 1947, Mines Act as applicable, Employees State Insurance Act 1948 and Maternity Benefit Act, 1961, Acts regulating P.F. or any modification thereof or any other law relating thereto and rules made there under from time to time, as may be applicable to the contract which may arise out of or in consequence of the construction or maintenance or performance of the work under the contract and also against costs, charges and expenses of any suit, action or proceedings arising out of any accident or injury.
- c) The company against all losses and claims for injuries or damages to any third party or to any property belonging to any third party which may arise out of or in consequence of the construction or maintenance or performance of the work under the contract and against all claims/demands proceedings/damages, cost charges and expenses whatsoever in respect of or in relation thereto
- xiv) Insurance - The contractor shall take full responsibility to take all precautions to prevent loss or damage to the works or part thereof for any reasons whatsoever (except for reasons which are beyond control of the contractor or act of God, e.g. flood, riots, war, earthquake, etc.) and shall at his own cost repair and make good the loss/damage to the work so that on completion, the work shall be in good order and condition and in conformity with the requirements of the contract and instructions of the Engineer-in-charge.

The contractor/contractors shall take following insurance policies during the full contract period at his own cost:

The contractor shall at all times during the tenure of the contract indemnify the company against all claims, damages or compensation under the provision of the Workmen's Compensation Act and shall take insurance policy covering all risk, claims, damages, or compensation payable under the Workmen's Compensation Act or under any other law relating thereto.

Compensation Act or under any other law relating thereto.

The contractor shall ensure that the insurance policy/ policies is/are kept alive till full expiry of the contract by timely payment of premiums and it/they shall not be can-

celled without the approval of the company and a provision is made to this effect in all policies, and similar insurance policies are also taken by his sub-contractors if any. The cost of premium shall be borne by the contractor and it shall be deemed to have been included in the tendered rate.

In the event of contractor's failure to effect or to keep in force the insurance referred to above or any other insurance which the contractor is required to effect under the terms of the contract, the company may effect and keep in force any such insurance and pay such premium/premiums as may be necessary for that purpose from time to time and recover the amount thus paid from any moneys due to the contractor.

THE CLAUSE 13(xviii) SHALL BE APPLICABLE FOR WORKS OF ESTIMATED VALUE OF OVER Rs. 50 LAKHS.

- xv) **Setting Out:** The contractor shall be responsible for the contract and proper setting out of the works and correctness.

The contractor shall have all necessary instruments, appliances and labour in connection therewith. If at any time during the progress of work any error is detected in respect of any part of the work, the contractor on being required to do so by the Engineer-in-Charge or his representative shall at the expenses of the contractor rectify such errors to the satisfaction of Engineer-in-Charge unless such error is due to incorrect data supplied by the Engineer-in-Charge.

- xvi) On receipt of Letter of Acceptance of Tender / Work Order the contractor shall forthwith Register and obtain necessary License(if required) from the competent authority under the Contract Labour (Regulation & Abolition) Act 1970,the Contract Labour (Regulation & Abolition) Central Rules, 1971 and submit certified copies of the same to the Engineer-in-Charge and the Principal Employer.

- xv) The contractor shall be registered with the concerned State Govt. and the Central Govt. in respect of Sales Tax Act and the certificate having details of Registration No.,period of validity etc.

- xvii) The contractor shall, in connection with works, provide and maintain safety and security of men and materials at his own cost.

- xviii) The contractor shall directly pay the ex-gratia amount of Rs.15.00 (Fifteen) lakhs to the eligible dependent family members of the deceased contractor's worker, who died in mine accident as certified by DGMS, to whom the statutory benefits under Employee Compensation Act, Provident Fund etc. have been paid, as per the terms of contract or through Insurance Company by availing Group Personal Accident Insurance Policy for all its workers before commencement of the contract, which shall be renewed periodically to cover the entire duration of the contract. No reimbursement shall be made on this account by CIL/Subsidiary.

In order to comply with the above provisions, contractor shall immediately on receipt of letter of acceptance/work order shall obtain group personal accident insurance in respect of all the workmen engaged in mining activities for payment of Rs.15.00(fifteen) lakhs in case of death in mine accident. A proof to such effect shall

be produced to the satisfaction of the management before commencement of the work. However, the responsibility of payment of special relief/ex-gratia amount shall lie exclusively with the Contractor.

If the contractor fails to disburse the special Relief/Ex-gratia within the due date, the subsidiary concerned may make payment to the eligible dependent as mentioned herein above. However, such amount shall be recovered from the Contractor from his dues either in the same and/or other subsidiaries of CIL.

13. Settlement of Disputes:

Disputes Resolution

1. Normally, there should not be any scope for dispute between the buyer / Company and seller / contractor after entering a mutually agreed valid contract. However, due to various unforeseen reasons, problems may arise during the contract, leading to a dispute between the buyer / Company and the seller / contractor. Therefore, the conditions governing the contract should contain suitable provisions for the settlement of such disputes or differences binding on both parties.
2. All disputes and differences between the parties, as to the construction or operation of the contract, or the respective rights and liabilities of the parties on any matter in question or any other account whatsoever, but excluding the Excepted Matters (detailed below); arising out of or in connection with the contract, within thirty (30) days from aggrieved Party notifying the other Party of such matters; whether before or after the completion/ termination of the contract, that cannot be resolved amicably between the Engineer-in-charge and the contractor within thirty (30) days from one party notifying the other of such matters, whether before or after the completion or termination of the contracts, shall be referred to as a "Dispute".
3. The aggrieved party shall give a 'Notice of Dispute' indicating the Dispute and claims, citing relevant contractual clauses to the Engineer-in-charge, and requesting to invoke the dispute resolution mechanisms as available in the contract.

Excepted Matters

Matters for which provision has been made in any clause of the contract shall be deemed as 'excepted matters' (matters not disputable), and decisions of the Company, thereon, shall be final and binding on the contractor. The 'excepted matters' shall stand expressly excluded from the purview of the Dispute Resolution Mechanism. However, where the Procuring Entity has raised the dispute, this sub-clause shall not apply. Unless otherwise stipulated in the contract, excepted matters shall include but not limited to:

1. Any controversies or claims brought by a third party for bodily injury, death, property damage or any indirect or consequential loss arising out of or in any way related to the performance of this Contract ("Third Party Claim"), including, but not limited to, a Party's right to seek contribution or indemnity from the other Party in respect of a Third-Party Claim.
2. Issues related to the pre-award tender process or conditions.
3. Issues related to ambiguity in contract terms shall not be taken up after a contract

has been signed. All such issues should be highlighted before the contractor signs the contract.

4. Issues related to contractual action/ termination of contract etc., by the Company on account of fraud, corruption, debarment of contractors, criminal or wilful negligence of the contractor etc.
5. Issues that are already under investigation by CBI, Vigilance, or any other investigating agency or government.
6. Provisions incorporated in the contract, which are beyond the purview of the Company or are in pursuance of policies of Government, including but not limited to
 - a) Provisions of restrictions regarding local content and Purchase Preference to Local suppliers in terms of the Make in India policy of the Government.
 - b) Provisions regarding restrictions on Entities from Countries having land-borders with India in terms of the Government's policies in this regard.
 - c) Purchase preference policies regarding MSEs and Start-ups

SETTLEMENT OF DISPUTES WITH THE CONTRACTOR

It is incumbent upon the contractor to avoid litigation and disputes during the course of execution. However, if such disputes take place between the contractor and the department, effort shall be made first to settle the disputes at the Company level.

The contractor should make request in writing to the Engineer-in-charge for settlement of such disputes/ claims within 30 (thirty) days of arising of the cause of dispute/ claim failing which no disputes/ claims of the contractor shall be entertained by the Company.

The dispute is to be resolved as per following stages:

In first stage dispute shall be referred as given below:

Scenario	The dispute shall be referred to:
For works executed at Area / sub-area / project level where Area GM is not Engineer-in-charge (EIC) and EIC is under the administrative control of Area GM:	Area GM
For works executed at Area / sub-area / project level and Area GM is Engineer-in-charge:	HOD(concerned department), Subsidiary HQ
For works executed at / through HQ level where HOD(concerned department) is not Engineer-in-charge (EIC) and EIC is under the administrative control of HOD	HOD (concerned department), Subsidiary HQ / CIL, as the case may be.
For works executed at / through HQ level and HOD(concerned department) is Engineer-in-charge	Serving officer not below the rank of HOD / E8, nominated by concerned Director.

If dispute still persist even after 60 days (extendable by another 30 days with mutual consent) of receipt of representation to Engineer-in-charge, then the Dispute shall be attempted to be resolved, as far as feasible, before recourse to courts, in the sequence as mentioned below, and the next mechanism shall not be invoked unless the earlier

mechanism has been invoked or has failed to resolve it within the deadline mentioned therein:

- a) Adjudication
- b) Mediation

NOTE: While processing a case for dispute resolution/ litigation, the Company may take legal advice at appropriate stages.

Adjudication

1. After exhausting efforts to resolve the Dispute in the first stage as mentioned above, the contractor shall give a 'Notice of Adjudication' specifying the matters which are in question or subject of the dispute or difference indicating the relevant contractual clause(s), as also the amount of claim (item-wise) to the concerned Director, Subsidiary / CIL for invoking resolution of the dispute through Adjudication.
2. Concerned Director Subsidiary / CIL can himself be the Adjudicator or can nominate an Adjudicator (a serving officer of Subsidiary / CIL not below the rank of HOD / E8, as the case may be).
3. During his adjudication, the Adjudicator shall give the contractor an adequate opportunity to present his case. Within 60 days (extendable by another 30 days with mutual consent) after receiving the representation, the Adjudicator shall make and notify decisions in writing on all matters referred to him. The parties shall not initiate, during the adjudication proceedings, any conciliation, arbitral (if available in the existing contracts) or judicial proceedings in respect of a dispute that is the subject matter of the adjudication proceedings.

NOTE: If differences still persist, the settlement of the dispute or differences relating to the interpretation and application of the provisions of commercial contract(s) between Central Public Sector Enterprise (CPSEs)/ Port Trusts inter se and also between CPSEs and Government Departments/ Organizations (excluding disputes relating to Railways, Income Tax, Customs & Excise Department), shall be taken up by either party for its resolution through Administrative Mechanism for Resolution of CPSEs Disputes (AMRCD) as mentioned in DPE OM No. 05/003/2019-FTS-10937 dated 14th December 2022 and the decision of AMRCD on the said dispute will be binding on both the parties.

For other contracts, if not satisfied by the decision in adjudication, or if the adjudicator fails to notify his decision within the above-mentioned time-frame, the contractor may proceed to invoke the process of Mediation as follows.

Mediation

- (i) Any party may invoke Mediation by submitting "Notice of Mediation" to the CMD of concerned Subsidiary / CIL. A neutral third party, known as the Mediator, facilitates the mediation process.
- (ii) **The Mediation Act and a Mediation Agreement:** The Mediation shall be conducted as per The Mediation Act 2023.
- (iii) **Guidelines for Mediation:** Department of Expenditure, Ministry of Finance has issued guideline on Mediation. Government departments/ entities/ agencies are encouraged to adopt mediation under the Mediation Act 2023 and/ or negotiate

amicable settlements to resolve disputes. Where necessary, e.g. matters of high value, they may proceed in the manner discussed below:

1. Company, may where they consider appropriate, e.g. in high-value matters (where amount of dispute / claim value is more than the DoP of concerned Director), constitute a High-Level Committee (HLC) (minimum 03 members) for dispute resolution, which may include the following (this composition is purely indicative and not prescriptive):
 - i. A retired judge.
 - ii. A retired high-ranking officer and/ or technical expert.
2. In cases where a HLC is constituted, the Company may either
 - i. negotiate directly with the other party and place a tentative proposed solution before the HLC or
 - ii. conduct mediation through a mediator and then place the tentative mediated agreement before the HLC or
 - iii. use the HLC itself as the mediator.
3. This will enable decisions taken for resolving disputes in appropriate matters to be scrutinized by a high-ranking body at arms-length from the regular decision-making structure, thereby promoting fair and sound decisions in the public interest, with probity.
4. There may be rare situations in long-duration works contracts where a renegotiation of the terms may best serve public interest due to unforeseen major events. In such circumstances, the terms of the tentative re-negotiated contract may be placed before a suitably constituted High-Level Committee before approval by the competent authority.
5. Disputes where the methods outlined above are unsuccessful should be adjudicated by the courts.

(iv) Appointment of Mediator(s):

1. Mediators can be of any nationality and must be registered with the Mediation Council of India (MCI) or empanelled by a court-annexed mediation centre or empanelled by an Authority constituted under the Legal Services Authorities Act, 1987 or empanelled by a mediation service provider (MSP) recognised by MCI.
2. Within 30 days of receipt of the "Notice of Mediation", the CMD of subsidiary / CIL after consultation with concerned Legal department shall propose names of three likely mediators from its panel, asking the other party to choose one as Mediator. The mutually accepted mediator shall then be appointed to conduct mediation.
3. If parties do not agree on the mediator, they can approach a mediation service provider ("MSP", recognised by MCI), who shall appoint a mediator based on the suitability and preferences of the parties within 7 days.
4. In contracts having an Integrity Pact, Independent External Monitors (IEMs) can be appointed as mediators, as per the Standard Operating Procedure (SOP) issued by the Central Vigilance Commission (CVC).

5. After a mediator is appointed, they must disclose any conflict of interest. Either party can seek a replacement of the Mediator after such disclosure.

(v) **Venue:** Mediation must be conducted within the territorial jurisdiction of the Court, which has jurisdiction to decide the dispute unless both parties agree to do it online or at the HQ of the subsidiary / CIL where the contract has been executed.

Online Mediation: The Act allows parties to opt for online/ virtual Mediation, which shall be deemed to occur within the jurisdiction of a competent court. The Act also requires online mediation communication mechanisms to ensure confidentiality.

(vi) The Process:

1. The Mediator independently and impartially encourages open communication and cooperation between disputing parties to reach an amicable settlement, but he does not have the authority to impose a settlement upon the parties to the dispute. The parties shall be informed expressly by the mediator that he only facilitates in arriving at a resolution of the dispute and that he shall not impose any settlement nor give any assurance that the mediation may result in a settlement.
2. Unlike court proceedings, Mediation is informal and flexible and allows for creative problem-solving and exploration of various solutions. The Code of Civil Procedure or the Indian Evidence Act, 1872 shall not be binding on the mediator.
3. Confidentiality: Subject to the other provisions of the Mediation Act 2023, the mediator, mediation service provider, the parties and participants in the mediation shall keep confidential all the following matters relating to the mediation proceedings, namely:—
 - i. acknowledgements, opinions, suggestions, promises, proposals, apologies and admissions made during the mediation;
 - ii. acceptance of, or willingness to, accept proposals made or exchanged in the mediation;
 - iii. documents prepared solely for the conduct of mediation or in relation thereto;
 - iv. any other mediation communication.
 - v. No audio or video recording of the mediation proceedings shall be made or maintained by the parties or the participants, including the mediator and mediation service provider, whether conducted in person or online, to ensure the confidentiality of the mediation proceedings.
4. The mediator initially meets the parties separately and communicates the view of each party to the other to the extent agreed upon by them. He assists them in identifying issues, advancing better understanding, clarifying priorities, and exploring areas of the parties' responsibility, identifying common interests, and encouraging compromise. He then meets them jointly to encourage a mutually acceptable resolution. At any stage of the mediation proceedings, at the parties' request, the mediator may suggest a dispute settlement in writing.

(vii) Termination of Mediation: The process must be completed within 120 days, though

parties can extend it by another 60 days through mutual consent. If Mediation is not completed within this timeline (120+60 days), the Mediator shall prepare a non-settlement report without disclosing the cause of non-settlement or any other matter or thing referring to their conduct during mediation for the parties or the MSP. Mediation shall also stand terminated on a declaration of the mediator, after consultation with the parties or otherwise, that further efforts at mediation are no longer justified or on communication by party(ies) in writing, addressed to the mediator and the other parties that they wish to opt out of mediation.

(viii) Mediated Settlement Agreement (MSA):

As per Section 49 of Mediation Act, Notwithstanding anything contained in this Act, no dispute including a commercial dispute, wherein the Central Government or State Government or any of its agencies, public bodies, corporations and local bodies including entities controlled or owned by them is a party, the settlement agreement arrived at shall be signed only after obtaining the prior written consent of the competent authority of such Government or any of its entity or agencies, public bodies, corporations and local bodies, as the case may be.

If the parties resolve the dispute and execute a mediated settlement agreement (“MSA”), then the Mediation is successful. An MSA is a written agreement settling some or all disputes and may extend beyond the disputes referred to mediation. It must be valid under the Indian Contract Act, signed by both parties and duly authenticated by the Mediator for the parties or the MSP. The Act provides options for MSA registration. During the pendency of proceedings, parties can also execute other agreements, settling some of the subject-matter disputes.

1. **Challenge to MSA:** MSA can be challenged within 90 days on limited grounds of (a) fraud, (b) corruption, (c) impersonation, and (d) subject matter being unfit for Mediation.
2. **Execution of MSA:** If there is no challenge or a challenge is unsuccessful, the Act ensures that the MSA is binding and enforceable, akin to a judgment or decree. This means that if one party fails to comply with the MSA, the non-defaulting party has a right to enforce it through the Court.
3. **Costs:** The parties shall equally bear all costs of mediation, including the fees of the mediator and the charges of the mediation service provider.
4. **No claim of Interest during Mediation proceedings:** Parties shall not claim any interest on claims/counter-claims from the date of notice invoking Mediation till the execution of the settlement agreement if so arrived. If parties cannot resolve the dispute, either party shall claim no interest from the date of notice invoking Mediation until the date of Termination of Mediation Proceedings.
5. The parties shall not initiate, during the mediation proceedings, any arbitral or judicial proceedings in respect of a dispute that is the subject matter of the mediation

proceedings.

14. E-way Bill:

The e-way bill required in connection with supply of goods or services, if any, shall be arranged by the supplier/vendor. However, the e-way bill will be arranged by CIL/Subsidiary if the supplier/vendor is unregistered one or if provisions of the relevant Act and the rules made there under specifically states that the e-way bill is required to be issued by recipient of goods.

15. Recovery: In the event of recovery of any claim towards LD Charges, Penalty, fee, fine or any other charges from the supplier/vendor, the same will be recovered excluding GST and the amount shall be adjusted with the payment to be made to the supplier/vendor against their bill/invoice or any other dues.

16. Provision of Electrical License :The contractor shall submit valid electrical license either in his name or of his authorized representative/supervisor [under whose supervision electrification work (internal and/or external) will be executed] issued by Electrical Licensing Board / Authority of the Indian State / UT, in accordance with Indian Electricity Rule before execution of electrical works, if any.

17. Guidelines on Debarment of firms from Bidding-

CIL and its Subsidiary Companies shall follow the following guidelines for effecting 'Debarment of firms from Bidding' with a contracting entity in respect of Works and Services Contracts.

- (i) Observance of Principle of Natural Justice before debarment of firm from Bidding. The bidder/contractor shall not be debarred unless such bidder/contractor has been given a reasonable opportunity to represent against such debarment (including personal hearing, if requested by the bidder/contractor).
- (ii) The terms 'banning of firm', 'Suspension', 'Blacklisting' etc. convey the same meaning as of 'Debarment'.
- (iii) The order of debarment shall indicate the reasons(s) in brief that lead to debarment of the firm.
- (iv) The contracting entity may be debarred from bidding in the following circumstances: -
 - a. Withdrawal of Bid as per relevant provisions of tender document.
 - b. If L-1 Bidder fails to submit PSD, if any and/or fails to execute the contract within stipulated period.
 - c. If L-1 Bidder fails to start the work on scheduled time.
 - d. In case of failure to execute the work as per mutually agreed work schedule.
 - e. Continued and repeated failure to meet contractual Obligations:
 - i. In case of partial failure on performance, agency shall be debarred from future participation in tenders keeping his present contract alive.
 - ii. On termination of contract.
 - f. Willful suppression of facts or furnishing of wrong information or manipulated or forged documents by the Agency or using any other illegal/unfair means.
 - g. Formation of price cartels with other contractors with a view to artificially hiking the price.
 - h. The contractor fails to maintain/ repair/ redo the work up to the expiry of

- performance guarantee period, when it is specifically brought to his notice.
- i. Contractor fails to use Mobilisation advance (if any) given to him for the purpose it was intended.
 - j. Contractor fails to renew the securities deposited to the department.
 - k. The contractor fails to rectify any lapse(s) in quality of the work done within defect liability period.
 - l. Transgression of any clause(s) relating to Contractor's obligation defined in the Integrity Pact wherever such Pact exists.
 - m. Any other breach of Contract or misdeed which may cause financial loss or commercial disadvantage to the Company.
 - n. If it is determined that the bidder has breached the Code of Integrity for Public Procurement (CIPP) as provided in the tender document.
 - o. False declarations w.r.t Make in India Order.
 - p. In case of supply of sub-standard materials, sub-standard quality of work, non-execution of work, non-supply of materials, failure to abide by bid securing declaration (if any) etc.
 - q. In case of price cartel, matter shall be reported to the Competition Commission and requesting, inter-alia, to take suitable strong actions against such firms.
- (v) Such 'Debarment, if any when effected, shall be with prospective effect only. The effect of 'Debarment' shall be for future tenders from the date of issue of such Order. No contract of any kind whatsoever shall be placed to debarred firm after the issue of a debarment order by DoE/MoC/CIL/Subsidiary (as applicable) if such debarment has been done before the last date of bid submission. Even in the case of risk purchase, no contract should be placed on such debarred firms.
- In case, any debarred firms have submitted the bid, the same will be ignored. In case such firm is lowest (L-1), next lowest firm shall be considered as L-1. Bid security/ EMD submitted by such debarred firms shall be returned to them.
- The contracts concluded i.e. issue of LOA/issue of work order, before the issue of the debarment order shall not be affected by the debarment orders.
- (vi) In case CIL is of the view that a particular firm should be banned across all the Ministries/ Departments by debarring the firm from taking part in any bidding procedure floated by the Central Government Ministries/ Departments, CIL may refer the case to MoC with the approval of Chairman, CIL for referring the case DoE with a self-contained note setting out all the facts of the case and the justification for the proposed debarment, along with all the relevant papers and documents.
- This shall be done only in those case where debarment has been done across CIL and its Subsidiaries.
- (vii) The debarment shall be for a minimum period of one year and shall be effective for the concerned Subsidiary for the tenders invited at Subsidiary level. Similarly, in case of tenders of CIL HQ, debarment shall be for CIL HQ. However, if such 'debarment' has to be made effective for entire CIL and its Subsidiaries then approval of Chairman, CIL shall be required. The period of debarment shall not exceed 02(Two) years. In case of

clause (4)(vi) & (xv) above, period of debarment shall be 02(Two) years.

(viii) Once a contracting entity is debarred, it shall be extended to the constituents of that entity, i.e. partners (jointly and severally) in case of Joint Venture, all the partners(jointly and severally) in case of Partnership Firm, owner/proprietor in case of Proprietorship Firm. The names of partners should be clearly specified in the Debarment Order. If such debarred owner/Proprietor/ Partner make/form different Firms/entity and attempts to participate in tenders, the same shall not be entertained during the currency of such debarment. In case the contracting entity being debarred is a Company then only the Company shall be debarred.

Note: "Company" means a company incorporated under Company's Act 2013 or under any previous company law.

(ix) The above 'Debarment' shall be in addition to other penal provisions of NIT/Contract document.

(x) Debarment in any manner does not impact any other contractual or other legal rights of CIL and/or its Subsidiaries.

(xi) In case of shortage of firms (less than three eligible firms) in a particular group, such debarments may also hurt the interest of CIL and/or its Subsidiaries. In such cases, endeavour should be to pragmatically analyse the circumstances, try to reform the firm and may get a written commitment from the firm that its performance will improve.

(xii) Approving Authority: The 'Debarment' of a contracting entity shall be done with the approval of the Competent Authority as per the details below:

a) In case the Accepting Authority of the work is Board or Empowered Committee or FDs or CMD of CIL/Subsidiary Company, then the Competent Authority for debarment shall be CMD of CIL/Subsidiary Company.

b) In case the Accepting Authority of the work is up to the level of Director of CIL/Subsidiary Company, then the Competent Authority for debarment shall be Director of CIL/Subsidiary Company.

(xiii) An order for debarment passed shall be deemed to have been automatically revoked on the expiry of that period and it shall not be necessary to issue a specific formal order of revocation.

A debarment order may be revoked before the expiry of the Order, by the competent authority, if it is of the opinion that the disability already suffered is adequate in the circumstances of the case or for any other reason.

(xiv) Appellate Authority for debarment orders shall be CMD of CIL/ Subsidiary Company. In case the debarment is done with the approval of CMD of the Subsidiary Company then Chairman, CIL shall be Appellate Authority. The appellate authority in case debarment is done with approval of Chairman CIL, shall be CFD of CIL.

(xv) Any change on the above may be done with approval of FDs of CIL.

(xvi) All the orders of debarment or orders passed in appeal shall be marked to GM(CMC) / ~~Civil~~ / concerned HODs of CIL/Subsidiary Company/ Application Admin of e-procurement portal of CIL/Nodal officers of Subsidiaries. Application Admin of e-

procurement portal of CIL/Nodal officers of Subsidiaries shall maintain the master data of such banned firms which shall be made available in the public domain (i.e. on the website of CIL/Subsidiaries/ e-Procurement portal of CIL).

@@@@@

ADDITIONAL TERMS AND CONDITIONS

1. Rates quoted by bidder shall remain firm for contract period, except variation allowed detailed below.

Application of Price Variation Clause.

If the prices of materials (not being the materials supplied at fixed issue rates by the company) and wages of labour required for execution of the work increase or decrease, the contractor shall be compensated for such increase or recoveries will be made from the bills for such decrease as per provisions detailed hereafter:

- a) The amount of the contract shall accordingly be varied subject to the condition that such compensation for escalation/ de-escalation in price shall be available only for the work done during the stipulated period of the contract including such period for which the contract is validly extended under the provisions of the contract without any penal action as detailed in clause no. 1.6. **The Price Variation Clause shall not be applicable for works for which stipulated period of completion is less than one year.**
- b) The base date for working out such escalation/de-escalation shall be the last date on which the bids (inclusive of price part) or revised price bids (inclusive of revised offer) were stipulated to be received.
- c) The compensation for escalation or recoveries to be made shall be worked out at quarterly intervals and shall be with respect to the cost of work done during the previous three months. The first such payment will be made at the end of three months after the month (excluding) in which the tender was accepted and thereafter at three months' interval
- d) Job specific modification in the formulae of price variation given in the following para(s) can be done with the approval of the CMD of the company

- 1.1 Escalation/ De-escalation for Labour:** The amount paid to the contractor for the work done shall be adjusted for increase or decrease in the cost of labour and the cost shall be calculated quarterly in accordance with the following formula :

$$VL = W \times \frac{A}{100} \times \frac{L-L0}{L0}$$

Where :

VL= Variation in labour cost i.e., increase or decrease in the amount in rupees to be paid or recovered.

W = Value of work done during the period under reckoning to which the escalation/de-escalation relates as indicated in clause-1.4 of the Additional Terms & Conditions of the contract.

- A = Component of labour expressed as percentage of the total value of the work adopted from the Table-1.
- Lo = Minimum wages for unskilled workers payable as per the Minimum Wages Act / Rules of the State or Central Govt., whichever is more, applicable to the place of work as on the last date stipulated for receipt of the bids (inclusive of price part) or revised price bids whichever is later.
- L = Revised minimum wages of unskilled worker corresponding to Lo during the period to which the escalation/de-escalation relates.

1.2 Escalation /De-escalation on Materials: The amount to be paid to the contractor for the work done will be adjusted for increase or decrease in the cost of materials and the cost shall be calculated quarterly in accordance with the following formula :

$$V_m = W \times \frac{B}{100} \times \frac{M - M_0}{M_0}$$

Where :

- V_m = Variation in the material cost i.e. increase or decrease in the amount in rupees to be paid or recovered.
- W = Cost of work done during the period under reckoning to which the escalation / de-escalation relates as indicated in clause-1.4 of the Additional Terms & Conditions of the contract.
- B = Component of material expressed as percentage of the total value of the work adopted from the Table -1.
- M = Average All India Wholesale Price Index for all commodities for the period to which escalation/de-escalation relates as published by the RBI Bulletin, Ministry of Industry & Commerce, Govt. of India.
- M₀ = All India Wholesale Price Index for all commodities as published by the RBI Bulletin, Ministry of Industry & Commerce, Govt. of India, relating to the last date on which the bids (inclusive of price part) or revised price bids whichever is later were stipulated to be received.

1.3 Escalation/ De-escalation on POL : The amount to be paid to the contractor for the work done shall be adjusted for the increase or decrease in the cost of POL and the cost shall be calculated quarterly in accordance with the formula given below :

$$V_f = W \times \frac{C}{100} \times \frac{F - F_0}{F_0}$$

Where :

- V_f = Variation in the cost of fuel, oil and lubricants increase or decrease in the rupees to be paid or recovered.
- W = Value of work done during the period under reckoning to which the escalation/ de-escalation relates as indicated in clause 1.4 of the Additional terms & Conditions of the contract.

C = Component of POL expressed as percentage of the total cost of the work taken from Table -1.

F = Average Index Number for wholesale price for the group of 'Fuel, Power, Light & Lubricants' as published by the Economic Adviser, Ministry of Industry, Govt. of India for the period to which the escalation/de-escalation relates.

F₀ = Index number of wholesale price for the group, Fuel, Power, light & lubricants as published by the Economic Adviser, Ministry of Industry, Govt. of India prevalent on the last date of receipt of bids (inclusive of Price Part) or revised price bids whichever is later.

1.4 While calculating the value of "W" the following may be noted : The cost on which the escalation will be payable shall be reckoned as 85 % of the cost of work as per the bills to which escalation relates, and from this amount the value of materials supplied or services rendered at the prescribed charges under the relevant provisions of the contract, and proposed to be recovered in the particular bill, shall be deducted before the amount of compensation for escalation or de-escalation is worked out. In the case of materials brought to site for which any secured advance is included in the bill, the full value of such materials as assessed by the Engineer-in-Charge (and not the reduced amount for which secured advance has been paid) shall be included in the cost of work done for operation of this clause. Similarly, when such materials are incorporated in the work and the secured advance is deducted from the bill, the full assessed value of the materials originally considered for operation of this clause should be deducted from the cost of the work shown in the bill, running or final. Further the cost of work shall not include any work for which payment is made at prevailing market rates.

1.5 In the event the price of materials and/ or wages of labour required for execution of the work decreases, there shall be downward adjustment of the cost of work so that such price of materials and/or wages of labour shall be deductible from the cost of work under this contract and in this regard the formulae herein before stated under this clause shall mutatis/mutandis apply. No such adjustment for the increase / decrease in material price and/ or wages of labour before mentioned would be made in case of contracts in which the stipulated period of completion of the work is less than one year.

1.6 Application of Price Variation Clause during extended period of Contracts.

The Price Variation Clause as stated above will be applied for extended time frame of a contract by following the principle stated as under:

- i) Normally, if and when it is understood that a contract is not going to be completed within the scheduled time period, the contract is kept operative by extending the time of completion provisionally. During this provisional extended period the operation of the Price Variation Clause will remain suspended.
- ii) If and when it is decided at the end of the successful completion of the work that the delay was due to causes not attributable to the contractor, then the Price Variation Clause will be revived and applied as if the scheduled date of completion has been shifted to the approved extended date.

- iii) If it is decided at the end of successful completion of the work that the delay was due to the fault of the contractor then the Price Variation Clause will not be revived for the purpose of escalation but shall be revived and applied for the purpose of de-escalation and no further payment will be made to the contractor on account of any escalation during this period but recovery shall be made for de-escalation, if any. Additionally, the Clause related to Compensation for delay will be applied.
- iv) If it is decided at the end of successful completion of work, the delay was partly due to the fault of the contractor and partly due to the fault of the employer and thereby Liquidated Damages (LD)/compensation due to delay is imposed then price variation clause for the purpose of escalation shall not be revived for this extended period, but shall be revived and applied for the purpose of de-escalation.

No payment will be made by applying “FROZEN INDICES “under any circumstances.

Table – 1

Value of A, B & C in the escalation formula in the additional terms & conditions for Excavation Works :

SI	Particulars	A% (Labour Component)	B% (Material Component)	C% (POL Component)	Remarks
1	For only labour oriented works of maintenance nature.	100	Nil	Nil	

For all other works not listed above, the component of labour, material and POL of the total cost of work shall be as specifically indicated in the tender document.

FIG 4000 TRACK FRAME

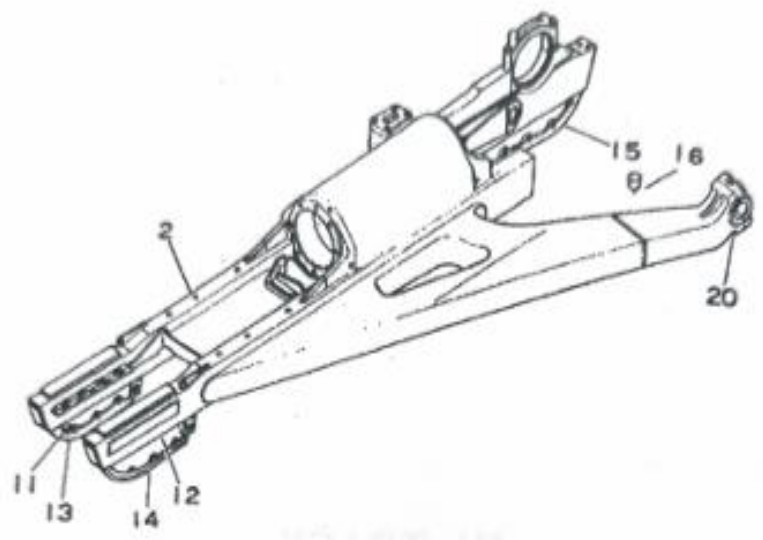

IV. TRACK

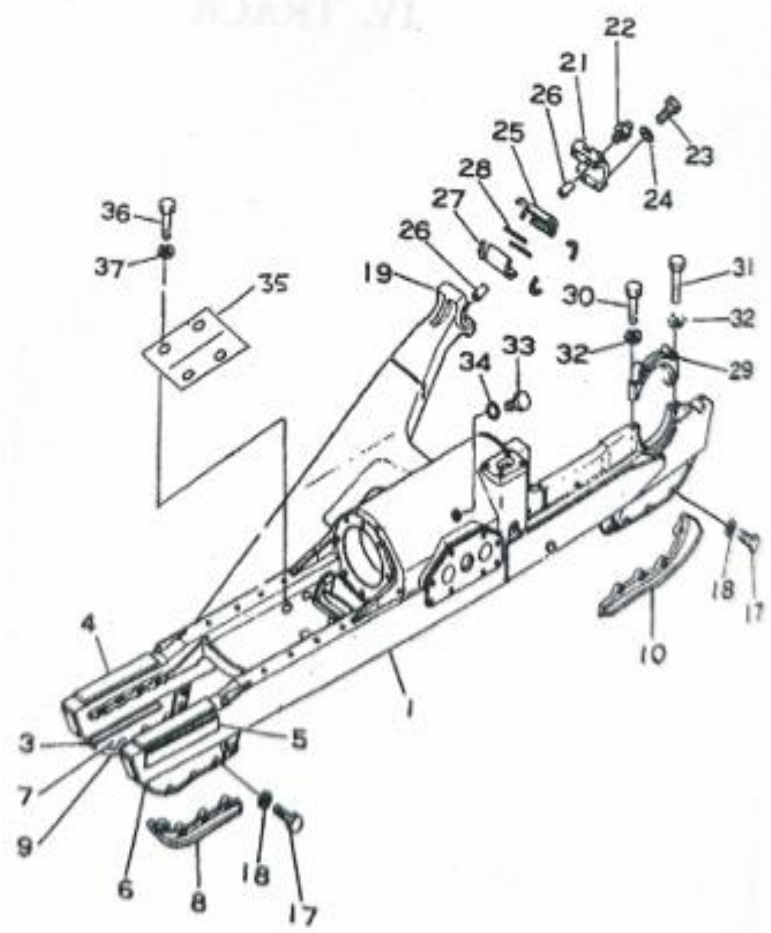

BD155

FIG 4000 TRACK FRAME

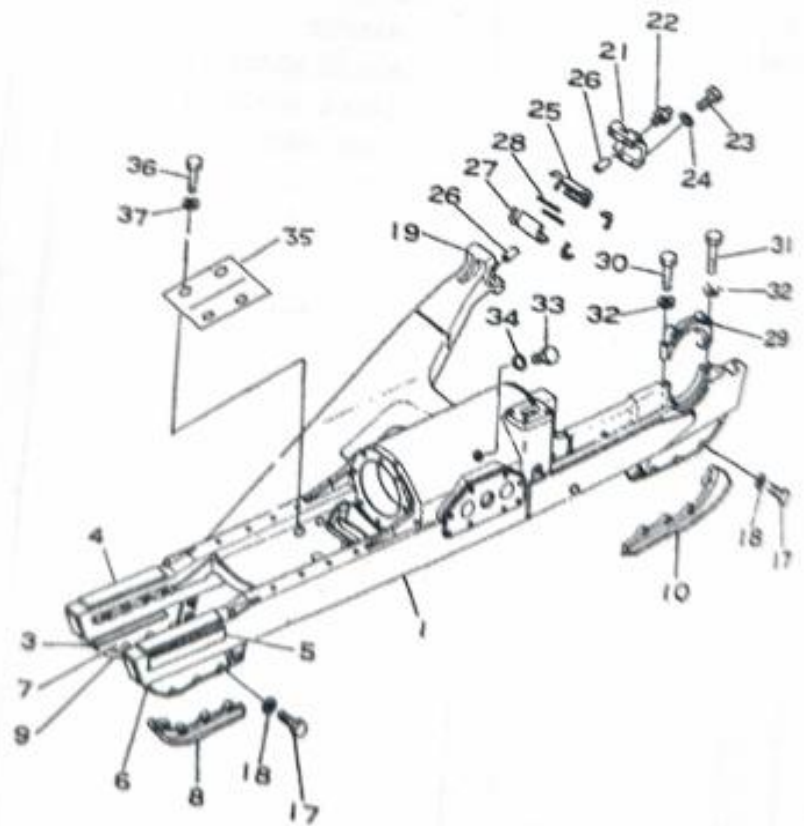
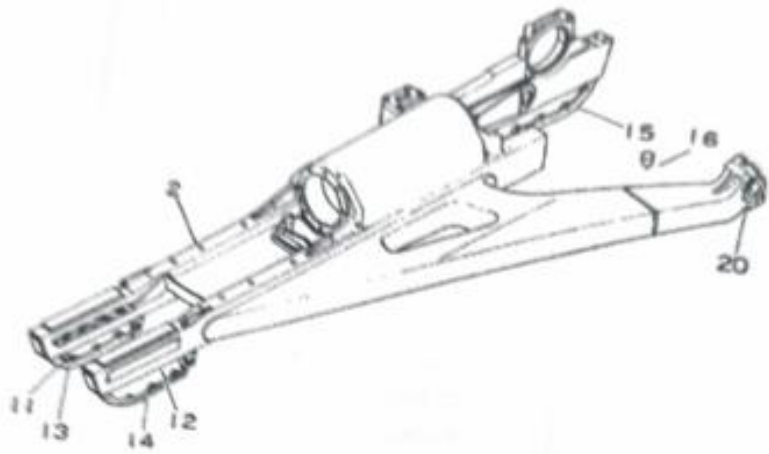

BD155

FIG 4050 TRACK ROLLER

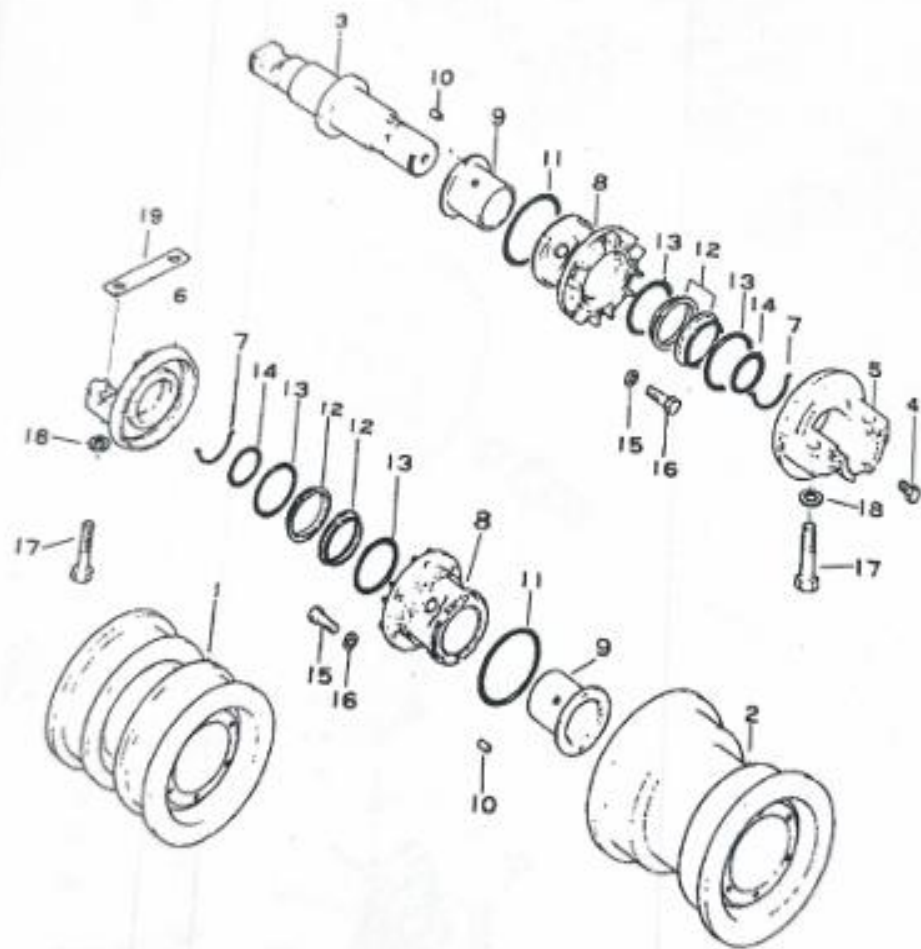

BD155

FIG 4060 CARRIER ROLLER

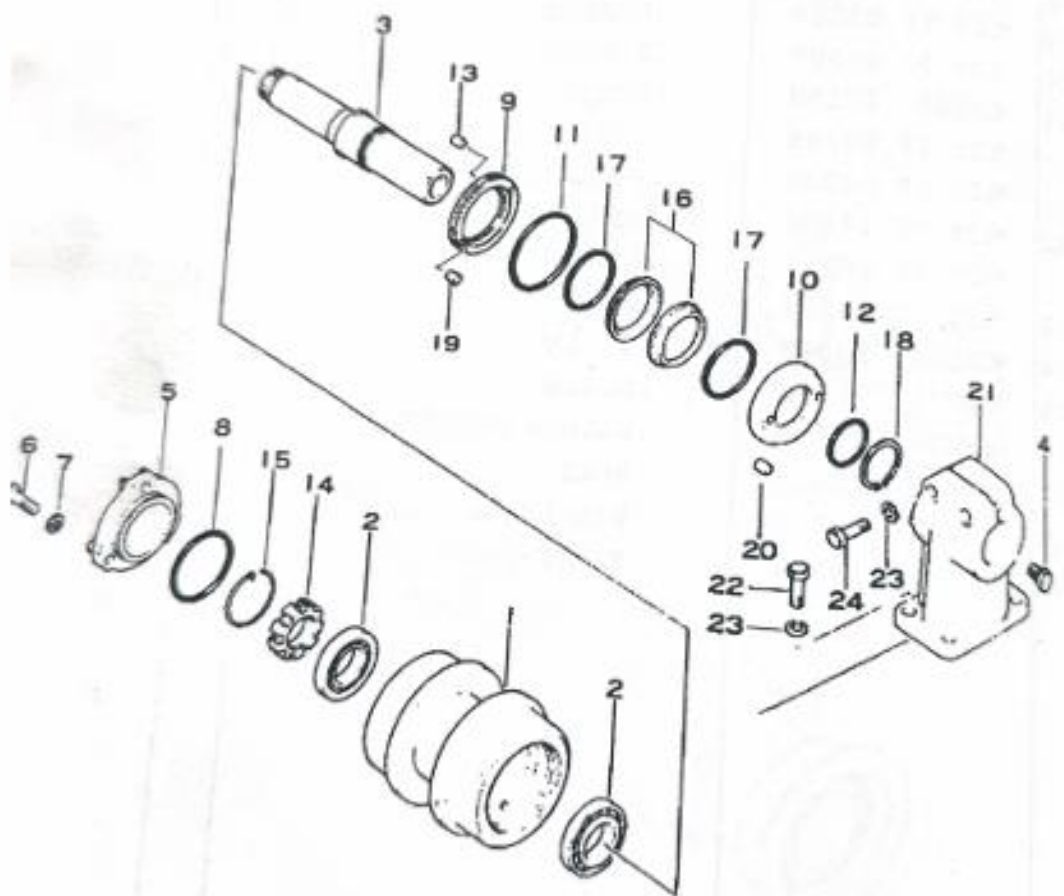

BD155

SPECIAL TERMS AND CONDITIONS (IF ANY)

2. Safety code:

i) The Contractor shall not employ men and women below the age of 18 years on the work of painting with products containing lead in any form. Wherever men above the age of 18 are employed on the work of lead painting, the following precaution should be taken:-

a) No paint containing lead or lead products shall be used except in the form of paste or ready-made paint.

b) Suitable face masks should be supplied for use by the workers when paint is applied in the form of spray or a surface having lead paint is dry rubbed and scrapped.

c) Overalls shall be supplied by the contractors to the workmen and adequate facilities shall be provided to enable the working painters to wash during and on the cessation of work.

d) Measures shall be taken, wherever practicable, to prevent danger arising out of from dust caused by dry rubbing down and scraping.

e) Adequate facilities shall be provided to enable working painters to wash during and on cessation of work.

f) Overall shall be worn by working painters during the whole of working period.

g) Suitable arrangement shall be made to prevent clothing put off during working hours being spoiled by painting materials.

ii) Use of hoisting machines and tackle including their attachments, anchorage and supports shall conform to the following standards or conditions:-

i) (a) These shall be of good mechanical construction, sound materials and adequate strength and free from patent defects and shall be kept repaired and in good working order.

(b) Every rope used in hoisting or lowering materials or as a means of suspension shall be of durable quality and adequate strength, and free from patent defects.

ii) Every crane driver or hoisting appliance operator, shall be properly qualified and no person under the age of 21 years should be in charge of any hoisting machine including any scaffolding winch or give signals to operator.

iii) In case of every hoisting machine and of every chain ring hook, shackle swivel and pulley block used in hoisting or as means of suspension, the safe working load shall be ascertained by adequate means. Every hoisting machine and all gear referred to above shall be plainly marked with the safe working load. In case of a hoisting machine having a variable safe working load each safe working load and the condition under which it is applicable shall be clearly indicated. No part of any machine or any gear referred to above in this paragraph shall be loaded beyond the safe working load except for the purpose of testing.

In case of departmental machines, the safe working load shall be notified by the Electrical Engineer-in-Charge. As regards contractor's machines the contractors shall notify the safe working load of the machine to the Engineer-in-Charge whenever he brings any machinery to site of work and get it verified by the Electrical Engineer concerned

iii) Motors, gearing, transmission, electric wiring and other dangerous parts of hoisting appliances should be provided with efficient safeguards. Hoisting appliances should be provided with such means as will reduce to the minimum the risk of accidental descent of the load. Adequate precautions should be taken to reduce to the minimum the risk of any part of a suspended load becoming

accidentally displaced. When workers are employed on electrical installations which are already energized, insulating mats, wearing apparel, such as gloves, sleeves and boots as may be necessary should be provided. The worker should not wear any rings, watches and carry keys or other materials which are good conductors of electricity.

iv) All scaffolds, ladders and other safety devices mentioned or described herein shall be maintained in safe condition and no scaffold, ladder or equipment shall be altered or removed while it is in use.

v) These safety provisions should be brought to the notice of all concerned by display on a notice board at a prominent place at work spot. The person responsible for compliance of the safety code shall be named therein by the contractor.

vi) To ensure effective enforcement of the rules and regulations relating to safety precautions the arrangements made by the contractor shall be open to inspection by the Labour Officer or Engineer-in-Charge of the department or their representatives.

vii) Notwithstanding the above clauses from (i) to (vii), there is nothing in these to exempt the contractor from the operations of any other Act or Rule in force in the Republic of India.

3. VTC Training

VTC training is a statutory requirement concerning the safety of contractor's labourers and for any work within Mines Area, only VTC trained labour shall be deployed by the contractor. The contractor shall follow extant law / guidelines in this regard and arrange for VTC training in respect of his workers who are not VTC trained.

4. The following safety operating practices (SOP) are to be adapted by the contractor for safely execution of the above work:

- a) All the manpower have to undertake vocational training (VTC) before starting the work.
- b) All the manpower have to keep I- Card issued by contractor during working time.
- c) Contractor has to submit the list of their work man with copy of their I-card, VTC training paper, form -B etc as per mine rules in the time office and work related concern section of office before starting the work (if applicable).
- d) You have to undertake the work which mentioned in the work order only.
- e) Every day attendance of manpower to be recorded in time office by the time keeper.
- f) Work to be performed under supervision of supervisor only.
- g) Contractor has to take entry and exit gate pass for vehicles, tools & tackles and other materials.
- h) The repairer and their manpower should abide all safety rules, mines rules applicable to the mines as per Mines act (as applicable).
- i) All the manpower's have to use wear safety gadget's like safety belts, helmet, safety shoe, leather apron, goggles ,leather hand gloves etc and it will be provided by the contractor.
- j) The gas cutters/cutting set should be attached with flash back fire arrester.
- k) Contractor have to use good quality of welding lead, welding holder and others accessories.
- l) Every time before starting and ending of work they have to inform the in-charge of m/c/ section in-charge.
- m) At the time of blasting the manpower are to be shifted to safe places till clearance of blasting.
- n) Suitable fire fighting accessories should be kept near working place before starting the welding/gouging/cutting etc which prone to caught the fire.
- o) Before starting of welding/cutting/gouging work the working area should be cleaned from grease, cardium, lube oil etc to avoid the caught of fire.
- p) After completion of welding/cutting/gouging work , the hot particle, slag, debris, job etc to be get completely extinct/extinguished before leaving the place.

.....

COMPLIANCE OF LABOUR LAWS

1. Labour

1.1 The Contractor shall, unless otherwise provided in the Contract, make his own arrangements for the engagement of all staff and labour, their payment, housing, feeding and transport.

The Contractor shall, if required by the Engineer, deliver to the Engineer a return in detail, in such form and at such intervals as the Engineer may prescribe, showing the staff and the numbers of the several classes of labour from time to time employed by contractor on the site and such information respecting contractor's equipment as the Engineer may require.

2. Compliance with Labour Regulations

2.1 During continuance of the contract, the contractor and his sub contractors shall abide at all times by all existing labour enactments and rules made thereunder, regulations, notifications and bye laws of the State or Central Government or local authority and any other labour law, including rules, regulations, bye laws that may be passed or notification that may be issued under any labour law in further either by the State or Central Government or the local authority.

The contractor shall keep the Employer indemnified in case any action is taken against the Employer by the competent authority on account of contravention of any of the provisions of any Act or rules made thereunder, regulations or notifications including amendments. If the Employer is caused to pay or reimburse, such amounts as may be necessary to cause or observe, or for non-observance of the provisions stipulated in the notifications by laws/acts/rules/regulations/including amendments, if any on the part of the contractor, the Engineer/Employer shall have the right to deduct any money due to the Contractor including his amount of performance security. The Employer/Engineer shall also have right to recover from the Contractor any sum required or estimated to be required for making good the loss or damage suffered by the Employer.

The employees of the contractor and the sub-contractor in no case shall be treated as the employees of the Employer at any point of time.

2.2 SALIENT FEATURES OF SOME MAJOR LABOUR LAWS APPLICABLE TO ESTABLISHMENT ENGAGED IN WORKS.

a) Workmen Compensation Act, 1923 :-

The act provides for compensation in case of injury by accident arising out of and during the course of employment.

b) Payment of Gratuity Act, 1972 :-

Gratuity is payable to an employee under the Act on satisfaction of certain conditions on separation if an employee has completed 5 years service or more or on death the rate of 15 days' wages for every completed year of service. The Act is applicable to all establishments employing 10 or more employees.

c) Employees PF and Miscellaneous Provisions Act, 1952 :-

The Act provides for monthly contributions by the employer and workers @10% or 8.33% or as applicable. The benefits payable under the Act are :

- i. Pension or family pension on retirement or death as the case may be.
- ii. Deposit linked Insurance on the death in harness of the worker.
- iii. Payment of PF accumulated on retirement/death etc.

d) Maternity Benefit Act, 1951 :-

The Act provides for leave and some other benefits to women employees in case of confinement or miscarriage etc.

e) Contract Labour (Regulation & Abolition) Act, 1970 :-

The Act provides for certain welfare measures to be provided by the contractor to contract labour and in case the contractor fails to provide, the same are required to be provided by the Principal Employer by Law. The Principal Employer is required to take Certificate of Registration and the contractor is required to take license from the designated Officer. The Act is applicable to the establishments or contractor of Principal Employer if they employ 20 or more contract labour.

f) Minimum Wages Act, 1948 :-

The Employer is supposed to pay not less than the Minimum Wages fixed by appropriate Government as per provisions of the Act if the employment is a scheduled employment. Construction of Buildings, Roads, Runways are scheduled employment.

g) Payment of Wages Act, 1936 :-

It lays as to by what date the wages are to be paid, when it will be paid and what deductions can be made from the wages of the workers.

h) Equal Remuneration Act, 1979 :-

The Act provides for payment of equal wages for work of equal nature of Male and Female workers and for not making discrimination against Female employee in the matters of transfers, training and promotion etc.

i) Payment of Bonus Act, 1965 :-

The Act is applicable to all establishments employing 20 or more workmen. The Act provides for payments of annual bonus subject to a minimum of 8.33% of wages and maximum of 20% of wages to employees drawing Rs. 3500/- per month or less. The bonus to be paid to the employee getting Rs. 2500/- per month to about upto Rs. 3500/- per month, shall be worked out by taking wages as Rs. 2500/- per month only. The Act does not apply to certain establishments. Some of the State Governments are exempted for five years in certain circumstances. Some of the State Governments have reduced the employment size from 20 to 10 for the purpose of applicability of the Act.

j) Industrial Disputes Act, 1947 :-

The Act lays down the machinery and procedure for resolution of Industrial disputes, in what situations a strike or lock-out becomes illegal and what are the requirements for laying off or retrenching the employees or closing down the establishment.

k) Industrial Employment (Standing Orders) Act, 1946 :-

It is applicable to all establishments employing 100 or more workmen (employment size reduced by some of the State and Central Government to 50). The Act provides for laying down rules governing the conditions of employment by the Employer on matters provided in the Act and get the same certified by the designated Authority.

l) Trade Union Act, 1926 :-

The Act lays down the procedure for registration of trade unions of workmen and employees. The Trade Unions registered under the Act have been given certain immunities from Excavation and criminal liabilities.

m) Child Labour (Prohibition & Regulation) Act, 1986 :-

The Act prohibits employment of children below 14 years of age in certain occupations and processes and provides for regulations of employment of children in all other occupations and processes. Employment of Child Labour is prohibited in Building Industry.

n) Inter-State Migrant Workmen's (Regulation of Employment & Conditions of Service) Act, 1997 :-

The Act is applicable to an establishment which employs 5 or more inter-state migrant workmen through an intermediary (who has recruited workmen in one state for employment in the establishment situated in another state). The Inter-State migrant workmen, in an establishment to which this Act becomes applicable, are required to be provided, certain facilities such as Housing, Medical-Aid, Travelling expenses from home up to the establishment and back etc.

o) The Building and Other Construction Workers (Regulation of Employment and Conditions of Service) Act, 1996 and the Cess Act of 1996 :-

All the establishments who carry on any building or other construction work and employs 10 or more workers are covered under this Act. All such establishments are required to pay cess at the rate not exceeding 2% of the cost of construction as may be modified by the Government. The employer of the establishment is required to provide safety measures at the Building or construction work and other welfare measures, such as canteens, First-Aid facilities, Ambulance, Housing accommodation for workers near the work place etc. The Employer to whom the Act applies has to obtain a registration certificate from the Registering Officer appointed by the Government.

p) Factories Act, 1948 :-

The Act lays down the procedure for approval at plans before setting up a factory, health and safety provisions, welfare provisions, working houses, annual earned leave and rendering information regarding accidents or dangerous occurrences to designated authorities. It is applicable to premises employing 10 persons or more with aid of power or 20 or more persons without the aid of power engaged in manufacturing process.



e-Tender Portal User Agreement

In order to create a user account and use the e-Tender portal you must read and accept this e-Tender portal User Agreement.

A. UNDERTAKINGS TO BE FURNISHED ONLINE BY THE BIDDER

I DO HEREBY UNDERTAKE

1. That all the information being submitted by me/us is genuine, authentic, true and valid on the date of submission of tender and if any information is found to be false at any stage of tendering or contract period, I/We will be liable to the following penal actions apart from other penal actions prescribed elsewhere in the tender document.
 - a. Cancellation of my/our bid/contract (as the case may be)
 - b. Forfeiture of EMD
 - c. Punitive action as per tender document
2. That I/we accept all terms and condition of NIT, including General Terms and Condition and Special/Additional Terms and Condition as stated there in the tender document as available on the website.
3. That I/we accept the Integrity Pact as given in the tender document (if applicable).
4. That I/we, am/are giving my/our consent for e-payment and submitting/ shall submit the mandate form for e-Payment in the format as prescribed in the document in case, the work is awarded to us.
5. That I/we do authorize CIL/Subsidiary for seeking information/clarification from my Bankers having reference in this bid.
6. That I/we will upload original/certified photo/scanned of all the relevant documents as prescribed in the tender document in support of the information and data furnished by me/us online.
7. I/We confirm that I/We have not been banned or de-listed by any Govt. or Quasi Govt. agencies or PSUs. In case We are banned or delisted this information shall be specifically informed to the tender issuing authority.
8. That I/We accept all the undertakings as specified elsewhere in the tender document.
9. That this online agreement will be a part of my bid and if the work is awarded to me/us, this will be a part of our agreement with CIL/Subsidiary Company.

B. TERMS AND CONDITIONS OF E-TENDER SERVICES AGREEMENT

COPYRIGHT NOTICE: Copyright©2013, Coal India Limited, India. All rights reserved.

YOU MAY NOT MODIFY, COPY, REPRODUCE, REPUBLISH, UPLOAD, POST, TRANSMIT, OR DISTRIBUTE, IN ANY MANNER, THE MATERIAL ON THE SITE, INCLUDING TEXT, GRAPHICS, CODE AND/OR SOFTWARE.

You may print and download portions of material from the different areas of the website solely for your own non-commercial use provided that you agree that you shall not change or delete any copyright or proprietary materials from the site.

You may print and download portions of material from the different areas of the website solely for your own non-commercial use provided that you agree that you shall not change or delete any copyright or proprietary materials from the site.

www.coalindiatenders.nic.in is an e-procurement portal of Coal India Limited / its Subsidiary.

THIS E-TENDER PORTAL AND RELATED SERVICES TO YOUR COMPLIANCE WITH THE USER'S TERMS AND CONDITIONS DET FORTH BELOW:

PLEASE READ THE FOLLOWING INFORMATION CAREFULLY. YOU MAY NOT COMPLETE YOUR REGISTRATION AND USE THE E-TENDER PORTAL WITHOUT AGREEING TO COMPLY WITH ALL OF THE TERMS AND CONDITIONS SET FORTH BELOW.

BY REGISTERING THE USER NAME AND PASSWORD, YOU AGREE TO ABIDE BY ALL THE TERMS AND CONDITIONS SET FORTH BELOW:

Bidder Registration, Password and Security:

Upon successful completion of Registration online, User ID and Password will be registered. You can login, only by giving valid User ID and Password and then signing with your valid Digital Signature Certificate.

The Online registration/enrolment of bidder on the portal should be done in the name of the bidder.

The person whose DSC is attached to the Registered Bidder should be either the bidder himself Or, duly authorized by the Bidder.

User ID and password are strictly personal to each Authorised User and non-transferable. The User shall ensure that its Authorised Users do not divulge or disclose their user ID or password to third parties. In the event that the Authorised User comes to know that the User ID/Password has been/might have been divulged, disclosed or discovered by any third party, user or its authorized user shall immediately modify the password using "Change Password" option. CIL/subsidiary will have no responsibility or obligation in this regard.

At the time of enrolment in the e-Tendering portal of CIL/its Subsidiaries, the Bidders should ensure that the status of DSC is active on this site. The activation of newly issued DSC may take 24 hrs or more. Hence Bidders who are obtaining new DSC should register at least 24 hrs before the submission of Bid.

By registering in this portal, you forthwith assume the responsibility for maintaining the confidentiality of the Password and account, and for all activities that occur under your Password or Account. You also agree to (a). immediately notify by e-mail to Application Administrator/Nodal officer, of any unauthorized use of your Password or Account or any other breach of security, and (b) ensure that you log-out from your account at the end of each session. CIL/its Subsidiaries shall not be liable for any loss or damage caused to you due to your failure to comply with the foregoing.

Registered user can modify or update some of the information in their profile as and when required at their own discretion. However, some information such as "User ID" are protected against changes by Bidder after enrolment and some other information such as "Bidder Name" etc. are protected against changes by Bidder after bid submission.

Modification of software:

With consent of Project Advisory Committee, e-procurement of CIL, the Administrator of e-Tender portal, reserves the right to modify, add, delete and/or change the contents, classification and presentation of the information on the market place at any time as it may in its absolute discretion find to be expedient and without giving any notice. It is the users responsibility to refer to the terms and/or any change or addition to the same while accessing the site.

Coal India Limited reserves right to interrupt/suspend the availability of the e-Tender system without any notice to the users.

System Requirements:

It is the user's responsibility to comply with the system requirements: hardware, software, Internet connectivity at user premises to access the e-Tender portal as mentioned in the home page in the link "Resources Required".

Under any circumstances, CIL shall not be liable to the Users for any direct/indirect loss incurred by them or damages caused to them arising out of the following:

- (a). Incorrect use of the e-Tender System, or;
- (b). Internet Connectivity failures in respect of the equipment used by the Users or by the Internet Service Providers, or;

(c). Inability of the Bidder to submit their bid due to any DSC related problems, hardware, software or any other factor which are personal/ special/local to the Bidder.

Contents of Tender Information:

Tenders shall be published by the authorized Tender Inviting Authorities of the respective Tendering entities of CIL/subsidiary. In case of any clarifications arising out of the tenders, the users have to contact the respective Tender Inviting Authority.

Bid Submission Acknowledgement:

The User should complete all the processes and steps required for Bid submission. The successful Bid submission can be ascertained once acknowledgement is given by the system through Bid Submission number i.e. Bid ID, after completion of all the processes and steps. Coal India Limited is not responsible for incomplete bid submission by users. Users may also note that the incomplete bids will not be saved by the system and so the same will not be available to the Tender Inviting Authority for processing.

The acknowledgment is the only confirmation of submission of bid, which the bidder can show as a proof of participating in the tender. Other than this acknowledgement, no proof will be considered as a confirmation to the submission of a bid. If the bidder fails to produce this acknowledgement required for verification in case of dispute, his claim for submission of bid may not be considered.

Upload files:

The bidders have to ensure that the files being uploaded by them are free from all kinds of viruses and contain only the relevant information as stated by the Tender Inviting Authorities for the particular tender. It is not obligatory on the part of CIL/subsidiary to read each and every document uploaded by the Bidder. If any bidder/Company has uploaded/attached irrelevant data, bogus or fabricated certificates towards his qualification requirements to the respective tender then their User account will be liable for termination permanently or temporarily by CIL/subsidiary without any prior notice.

User Conduct:

You agree that all information, data, text, software, photographs, graphics, messages or other materials ("Content"), whether publicly posted or privately transmitted, are the sole responsibility of the person from which such Content is originated. This means that you are entirely responsible for all Content that you upload, post, email or otherwise transmit via the e-Tender portal.

CIL/subsidiary does not control the Content posted via the e-Tender portal and, as such, does not guarantee the accuracy, integrity or quality of such Content. Hence under no circumstances, CIL/subsidiary is liable in any manner for any Content, including, but not limited to, for any errors or omissions in any Content, or for any loss or damage of any kind incurred as a result of the use of any Content posted, e-mailed or otherwise transmitted via the Site.

Amendments to a tender published:

You agree that the CIL/ Subsidiary companies reserves the right to re-tender /cancel a tender or extend the closing date or amend the details of tender at any time by publishing corrigendum as applicable.

Special Admonitions for International Use:

Recognizing the global nature of the Internet, you agree to comply with all local rules regarding online content and acceptable Content. Specifically, you agree to comply with all applicable laws regarding the transmission of technical data to and from India or the country in which you reside.

Links:

The Site may provide, links to other World Wide Web sites or resources. Because CIL/subsidiary has no control over such sites and resources, you acknowledge and agree that the CIL/Subsidiary is not responsible for the availability of such external sites or resources, and does not endorse and is not responsible or liable for any Content, advertising, products, or other materials on or available from such sites or resources.

You further acknowledge and agree that the CIL/subsidiary shall not be responsible or liable, directly or indirectly, for any damage or loss caused or alleged to be caused by or in connection with use of or reliance on any such Content, Goods or Services available on or through any such site or resources.

Miscellaneous:

This Agreement shall all be governed and construed in accordance with the laws of India & applicable to agreements made and to be performed in India. The e-Tender portal's failure to insist upon or enforce strict performance of any provision of this Agreement shall not be construed as a waiver of any provision or right. Neither the course of conduct between the parties nor trade practice shall act to modify any provision of this Agreement. CIL/subsidiary may assign its rights and duties under this Agreement to any party at any time without notice to you. Any rights not expressly granted herein are reserved.

Governing Law:

Terms shall be governed by, and construed in accordance with, Indian law. The parties agree that the principal civil court of the place where the registered office of Coal India/Subsidiary Company is situated shall have non-exclusive jurisdiction to entertain any dispute with Coal India/Subsidiary company. In case of dispute being with a regional Institute of CMPDIL, the principal Civil Court where the said regional Institute is situated shall be place of suing.

CIL/subsidiary reserves the right to initiate any legal action against those bidders violating all or any of the above-mentioned terms & conditions of e-Tender services agreement.

Modification of terms of Agreement:

CIL/its Subsidiaries reserves the right to add to or change/modify the terms of this Agreement. Changes could be made by us after the first posting to the Site and you will be deemed to have accepted any change if you continue to access the Site after that time. CIL/its Subsidiaries reserves the right to modify, suspend/cancel, or discontinue any or all services/ make modifications and alterations in any or all of the content, at any time without prior notice.

Policy and Security:

General Policy:

CIL/its Subsidiaries is committed to protecting the privacy of our e-Tender site visitors. CIL/subsidiary does not collect any personal or business information unless you provide it to us voluntarily when conducting an online enrolment, bid submission etc. or any other transaction on the Site.

Information Collected:

When you choose to provide personal or business information to us to conduct an online transaction, we use it only for the purpose of conducting the specific online transaction that you requested. The information is also used for the purpose of vendor searches. For each online transaction, we require only a minimum amount of personal and business information required to process your transaction.

When you visit our portal to browse, read pages, or download information, we automatically collect and store only the following information:

The Internet domain and IP address from which you access our portal;

The date and time you access our portal;

The pages you visit

This information would help us to make our site more useful to visitors and to learn about the number of visitors to our site and the types of technology our visitors use.

We do not give, share, sell or transfer any personal information to a third party unless required to do so by law. If you do not want any personal or business information to be collected, please do not submit it to us; however, without this required information we will be unable to process your

online bid submission or any other online transaction. Review, update and correction of any personal or business information can be done directly on the Site.

Use of Cookies:

When you choose to enter into an online transaction, we use cookies to save the information that you input while progressing through the transaction. A cookie is a very small amount of data that is sent from our server to your computer's hard drive. By enabling this feature, the cookie will remember the data entered by you and next time when you visit this site, the data stored in the cookie will be available in future.

Security:

The Site has security measures in place to protect against the loss, misuse and alteration of information under our control.

e-Mail/ SMS Notifications:

The GePNIC eProcurement Server has functionality of automatically sending e-Mail / SMS alerts at various events as per the bidders preference. There is no manual intervention while sending these pre-defined e-Mail / SMS alerts. All events for which e-Mails / SMS being sent is also available to users on the Dash Board / the user login of the Bidder. Although all efforts will be made to ensure timely delivery of e-Mail / SMS, due to dependency in various other external factors, the delivery of e-Mail / SMS may not be assured and bidders are requested to check the portal on a periodic basis for any such events. Non receipt of e-Mail / SMS cannot be quoted as a reason for failure of service as this is an added facility being provided to users.

ANNEXURES

PROFORMA FOR LETTER OF BID TO BE ACCEPTED UNCONDITIONALLY BY BIDDER DURING SUBMISSION OF BID ONLINE: (TO BE ACCEPTED THROUGH GTE)

FORMAT OF "Letter of Bid"

To,
The Tender Inviting Authority,
Central Coalfields Limited.
Sub. : Letter of Bid for the work ".....".
Ref. : 1. NIT No.:
2. Tender Id No. : ".....".

Dear Sir,
This has reference to above referred bid. I/we have read and examined the conditions of contract, Scope of Work, technical specifications, BOQ and other documents carefully.

I /We am/are pleased to submit our bid for the above work. I/We here by unconditionally accept the bid conditions and bid documents as available in the website/e-Procurement portal, in its entirety for the above work and agree to abide by and fulfill all terms and conditions and specifications as contained in the bid document.

I/we here by submit all the documents as required to meet the eligibility criteria as per provision of the bid notice/document.

I/We hereby confirm that this bid complies with the Bid validity, Bid Security and other documents as required by the Bidding documents.

If any information furnished by me/us towards eligibility criteria of this bid is found to be incorrect at any time, penal action as deemed fit may be taken against me/us for which I/We shall have no claim against CIL/Subsidiary.

Until a formal agreement is prepared and executed, this bid and your subsequent Letter of Acceptance/Work Order shall constitute a binding contract between us and Central Coalfields Ltd.

Should this bid be accepted, we agree to furnish Performance Security within stipulated date and commence the work within stipulated date. In case of our failure to abide by the said provision Central Coalfields Ltd. shall, without prejudice to any other right or remedy, be at liberty to "cancel the letter of acceptance/ award and to forfeit the Earnest Money and also debar us from participating in future tenders for a minimum period 12 months" OR to act as specified in the NIT.

PROFORMA FOR UNDERTAKING TO BE ACCEPTED UNCONDITIONALLY BY BIDDER/S FOR GENUINENESS OF THE INFORMATION FURNISHED ONLINE AND AUTHENTICITY OF THE DOCUMENTS UPLOADED ONLINE IN SUPPORT OF HIS ELIGIBILITY :(TO BE ACCEPTED THROUGH GTE)

We solemnly declare that:

1. I/We am/are submitting Bid for the work “.....” against Tender id No.....Datedand I/we offer to execute the work in accordance with all the terms, conditions and provisions of the bid.
2. All information furnished by us in respect of fulfilment of eligibility criteria and qualification information of this Bid is complete, correct and true.
3. All copy of documents, credentials and documents submitted along with this Bid are genuine, authentic, true and valid.
4. I/ We hereby authorize department to seek references / clarifications from our Bankers.
5. We hereby undertake that we shall register and obtain license from the competent authority under the contract labour (Regulation & Abolition Act) as relevant, if applicable.
6. I/We do not have business relationship with any other participating Bidders, directly or through common third parties, that puts us in a position to have access to information about or influence on the bid of another Bidder.
7. I/We or any of my/our affiliate has/have not participated as consultant in the preparation of the design or technical specification of the contract that is the subject of the bid.
8. If any information and document submitted is found to be false/ incorrect at anytime, department may cancel my/our Bid and action as deemed fit may be taken against me/us, including termination of the contract, forfeiture of all dues and Debarment of our firm and all partners of the firm etc from Bidding, as per the tender document.

ANNEXURE- III

PROFORMA FOR UNDERTAKING TO BE UPLOADED BY BIDDER/S (ON THEIR LETTER HEAD) REGARDING RELATIVES AS EMPLOYEES OF COMPANY, LOCAL SUPPLIER STATUS OF THE BIDDER ETC.: PROFORMA FOR UNDERTAKING

(To be uploaded by the Bidder on his Letter Head during submission of bid online)

I / We,, Proprietor/Partner/Legal Attorney/Director/ Accredited Representative of M/s., solemnly declare that:

1. Myself/Our Partners/Directors don't has/have any relative as employee of Central coalfields Limited.

OR

The details of relatives of Myself/Our Partners/Directors working as employee of Coal India Limited is as follows:

a) Name of the employee

b) Place of posting

c) Department

d) Designation

e) Type of relation - Wife/Husband/ Father/ Step-Father/Mother / Step-Mother/ Son/Step-son/ Son's wife / Daughter / Daughter's Husband / Brother/ Step-Brother/ Sister / Stet-Sister.

2. *I/We hereby confirm that we have registration with CMPF / EPF Authorities. We shall make necessary payments as required under law.

Or

*I/We hereby undertake that we shall take appropriate steps for registration as relevant under CMPF / EPF authorities, if applicable. We shall make necessary payments as required under law.

* Delete whichever is not applicable.

3. ** I/We have not been debarred or banned or delisted by any Govt., or Quasi Govt. Agencies or PSUs.

Or

**I / Wehave been debarred or banned by the organization named " _____ " for a period of..... year/s, effective from to.....

** Delete whichever is not applicable.

4. We certify that the works/services offered by us against the tender for the work of "....." against Tender id NoDated, meet the minimum local content requirement and has local content:

* Equal to or more than 50% (Select this, in case of Class-I Local Suppliers) i.e.....% (indicating the percentage of local content) * More than 20% but less than 50% (Select this, in case of Class-II Local Suppliers) i.e.....% (indicating the percentage of local content)

*Delete whichever is not applicable.

Note: If the estimated value of procurement is more than Rs. 10 crores, all the Bidders shall submit along with this Undertaking, a certificate (with UDIN) from the statutory auditor or cost auditor of the company (in case of companies) or from a practicing cost accountant or practicing chartered account (in respect of suppliers other than companies) giving the percentage of local content.

5. Certificate regarding compliance to order no.F.No.6/18/2019-PPD dt 23/7/2020 as amended from time to time of Ministry of Finance, Dept of Expenditure, Public Procurement Division with respect to restrictions on procurement of goods, services or works from a Bidder of a country

which shares a land border with India and on sub-contracting to contractors from such countries - I/we have read the

Clause regarding restrictions on procurement from a Bidder of a country which shares a land border with India and on sub-contracting to contractors from such countries; I/we certify that I am/ we are not from such a country or, if from such a country, has/have been registered with the Competent Authority and will not subcontract any work to a contractor from such countries unless such contractor is registered with the Competent Authority. I hereby certify that I/we fulfil all requirements in this regard and I am/ we are eligible to be considered.

Note: Where applicable, evidence of Competent Authority shall be attached along with this Undertaking.

6. **I/We have not been debarred by any procuring entity for violation of Preference to Make in India (as applicable) vide Order No. P-45021/2/2017-PP (BE-II) dated 16.09.2020, issued by Govt. of India as amended from time to time.

OR

**I / Wehave been debarred by.....(name of procuring entity) for violation of Preference to Make in India vide Order No. P-45021/2/2017-PP (BE-II) dated 16.09.2020, issued by Govt. of India as amended from time to time for a period of.....year/s, effective from to.....

**Delete whichever is not applicable.

Note: A bidder who has been debarred by any procuring entity for violation of Preference to Make in India vide Order No. P-45021/2/2017-PP (BE-II) dated 16.09.2020, issued by Govt. of India as amended from time to time shall not be eligible for preference under this Order for procurement by any other procuring entity for the duration of debarment.

7. I/we abide the Code of Integrity for Public Procurement (CIPP) as given in the tender document.

8. *I/we do not have any previous transgression of CIPP in last three years with any entity in any country.

Or

*I / We have been debarred by.....(name of procuring entity) for violation of Code of Integrity for Public Procurement (CIPP), for a period of..... year/s, effective from to.....

*Delete whichever is not applicable

9. If any information and document submitted is found to be false/ incorrect at any time, department may cancel my/our Bid and action as deemed fit may be taken against me/us, including termination of the contract, forfeiture of all dues and Debarment of our firm and all partners of the firm etc from Bidding, as per the tender document.

PROFORMA FOR EXECUTION OF AGREEMENT.

(Specimen to be vetted by Legal Department))

STAMP PAPER

(of appropriate value as per Stamp Act)

This agreement is made on day of between (Name of Company) having its registered office at (hereinafter called the 'COMPANY' which expression shall, unless repugnant to the subject or context, include its successors and assignees) of the one part and (Name of the Contractor) carrying on business as a (partnership/ proprietorship/ Ltd. Co. etc.) firm under the name and style (hereinafter called the 'said Contractor' which expression shall, unless the context requires otherwise include them and their respective heirs, executors, administrators and legal representatives) of the other part.

Whereas the Company invited tenders for the work of "....." and whereas the said Contractor/ Firm submitted tender for the said work and deposited a sum of Rs..... as Earnest Money and whereas the tender of the said contract has been accepted by the Company for execution of the said work.

NOW THIS AGREEMENT WITNESSETH AS FOLLOWS:

- 1) In this agreement words and expressions shall have the same meaning as are respectively assigned to them in the tender papers hereinafter referred to.
- 2) The following documents which are annexed to this agreement should be deemed to form and be read and construed as part of this agreement viz.
 - i) Annexure-A Tender Notice (Page .. to ..)
 - ii) Schedule –A General Terms & Conditions, Special Conditions and General Technical Specification (Page to ...) and Safety Code.
 - iii) Schedule-B The probable Quantities and Amount (Page ... to ...)
 - iv) Schedule-C Negotiation letters –
 - iv) Schedule-D Letter of Acceptance/Work Order (Page .. to ..)
 - v) Schedule-E Drawings (Page .. to ..)
- 3) In consideration for the payment of the sum of Rs.....(W/O Value; both in words and figures) or such other sum as may be arrived at under the clause of the specification relating to Payment by items measurements at unit prices by the Company, the said Contractor shall, subject to the terms & condition contained herein execute and complete the work as described and to the extent of probable quantities as indicated in Schedule B with such variations by way of alteration, addition to or reduction from the said works.
- 4) The company has received a sum of Rs..... towards Performance Security Deposit (1st part of Security Deposit) in the form of B.G./NEFT/RTGS *other form (details to be furnished)* .
- 5) The said contractor hereby covenants with the company that the company shall deduct at 5% of R/A Bills excluding GST as Retention Money (2nd part of security deposit) as per the terms & condition of the tender/ contract.

IN WITNESS WHEREOF THE parties herein have set their hands and seals the date and year above written

1 Partner. Signature

2 Partner Signature

On behalf of M/S.....

The Contractor, as one of the constituted attorney,
In the presence of –

1. Name _____ Signature

Address :

Occupation :

Signed by Srion behalf of Signature
(Name of Company) in presence of -

1. Name : Signature
2. Address: .

**WORK ORDER
(Specimen Form Contents)**

..... COALFIELDS LTD

(A subsidiary of Coal India Limited)

Office of the

Address.....

Ref. No:.....

Date:

To

M/s

.....

Dear Sir,

Sub : Work Order for

Ref. i) Your offer opened on.....in response to Quotation/Bid Notice

No.....

ii) Your Negotiation letter No..... (if any).

iii) LOA No..... (if any)

1. Pursuant to the above Quotation/Bid Notice, Quotation/Bids were invited for the above-mentioned work and were opened on..... in the presence of intending Quotationer/Bidders or their representatives and you had submitted a Quotation/Bid in response to the aforesaid Quotation/Bid Notice as per the terms and conditions stipulated for submission of Quotation/Bid which shall form part of this Work Order.
2. The management of Coalfields Ltd. having decided to award the work in your favour, the work is awarded to you for a period ofdays/ months at a cost of Rs..... .

Work Description: Name of Work with location.

Enclose Bill of Quantities duly filled in as per accepted bid/quotation along with scope of work and notice.

The above work is awarded to you on the following terms and conditions:-

a) The date of start of work shall be 10th day of issue of letter of acceptance/work order.

b) Security Deposit:

Performance Security Deposit @ 5% will have to be deposited by you within 21 days of issue of LOA/work order. You have already deposited a sum of Rs..... as earnest money, which shall be converted into performance security and as such, the balance amount of Rs.....is to be deposited in shape of BG/NEFT/RTGS/other forms in favour of Coalfields Ltd on any Scheduled Commercial Bank payable at its Branch at.....

Retention Money will be deducted at 5% from your running bills. Total of performance security and Retention Money should not exceed 10% of awarded value/ revised completion value.

The performance security deposit shall be refunded after successful completion of the work and issue of Defect Liability Certificate (taking over certificate with a list of defects.)

The retention money will be refunded after expiry of Defect Liability Period, issue of 'No-defect' Certificate and payment of final bill.

However, for maintenance works, where work is of such nature that there is no question of defect, the retention money will be refunded after completion of work along with refund of performance security. The security deposit shall bear no interest.

c) Payment of Bills

Monthly running account bills shall be paid based on measurement of work recorded by the official authorized by the department for this purpose.

Note: Further statutory deductions as per norms shall be effected.

d) Statutory Obligations - on Contractor's Account

The contractor shall maintain all records as per the provision made in various statutes including contract/labour regulation and abolition act and pay minimum wages to the labourer engaged by him as per minimum wages act or such other legislation or award of the minimum wage fixed by the respective state govt. or central govt. as may be in force.

The company does not undertake any responsibility for supply of any material and tools and plants. The contractor shall arrange all material, tools and plants and labour required for the work.

e) Penal Clauses/ Recovery of Damages.

The work shall be started within 10 days of issue of Letter of Acceptance/Work order or 7th day of handing over of the site whichever is earlier. The work shall be completed within.....months/days as specified in quotation/bid notice.

In case of failure to complete the work on or before the scheduled date of completion, compensation shall be payable @ 0.5% of contract price/revised contract price whichever is less per week of delay. The total value of such compensation shall not exceed 10% of awarded value/ revised completion value whichever is lower.

In case of failure to start the work within 10 days of issue of LOA/work order, the company shall be at liberty by giving 10 days notice in writing to start the work, failing which to forfeit the earnest money deposited by you and to rescind the LOA/work order. Additionally you will be debarred from participating in future tenders for period of 1(one) year.

f) Change in Scope/ Nature of Work During Progress of Work

In case of any change/deviation in quantity and items of the work during its progress, the contractor is to inform the management immediately and act as per the direction of the management.

g) Termination/ Cessation of Work with Notice

The management reserves the right to terminate the contract under the following specific conditions/ circumstances:

- a. Unsatisfactory performance of the contracted work
- b. Involvement in action causing breach of peace and discipline within the company/area premises.
- c. Failure to comply with the general terms and conditions of MCEW which is integral part of the work order.
- d. Moral turpitude
- e. Violation of the provisions under various laws and awards in force from time to time as are applicable to the work
- f. Any action on the part of the contractor which in the opinion of the management is detrimental to the interest of the company.

h) Payment of Government Dues Connected with the Work

The contractor is required to make timely payment of government dues which he is under legal obligation to pay to state government or any other legal authority every month.

i) Contractor's Representation at Site.

The contractor shall depute himself /his agent/ representative at the work site during the period of contract. Intimation in this regard be submitted to the department. The contractor/agent/representative shall receive instruction from the department.

In addition to all the above terms and conditions, the award shall be guided by standard General Terms and Conditions as per provision of MCEW (as enclosed) that are integral part of the work order-cum-agreement.

The work order is being issued to you in duplicate. Please return the duplicate copy duly signed on all pages, as a token of your acceptance which shall be treated as an agreement between you and company.

Yours faithfully,

Designation

NOTES :

1. *Draft Work Order is only a specimen form content.*
2. *Additional clauses e.g. Penal clauses/ recovery of damages, termination clauses, etc. may be inserted according to the requirement in a particular case.*
3. *This draft is applicable for works where agreement is not likely to be executed.*
4. *For works where separate agreement shall be executed this draft may be considered as broad guidelines with suitable modifications / adjustment.*

PRE-CONTRACT INTEGRITY PACT

General

This pre-bid pre-contract Agreement (hereinafter called the Integrity Pact) is made on.....day of the month of20..., between, on one hand, Coal India Limited/Subsidiary Cos. acting through Shri, Designation of the officer, (hereinafter called the “BUYER / Principal”, which expression shall mean and include, unless the context otherwise requires, his successors in office and assigns) of the First Part and M/s.represented by Shri....., Chief Executive Officer (hereinafter called the “BIDDER/Seller/Contractor” which expression shall mean and include, unless the context otherwise requires, his successors and permitted assigns) of the Second Part.

WHEREAS the BUYER proposes to procure(Name of the Work/Stores/Equipment/Item) and the BIDDER/Seller is willing to offer/has offered the stores and

WHEREAS the BIDDER is a private company/public company/Government undertaking/partnership/registered export agency, constituted in accordance with the relevant law in the matter and the BUYER is a Central Public Sector Unit.

NOW, THEREFORE,

To avoid all forms of corruption by following a system that is fair, transparent and free from any influence/prejudiced dealings prior to, during and subsequent to the currency of the contract to be entered into with a view to :-

Enabling the BUYER to obtain the desired said work/stores/equipment at a competitive price in conformity with the defined specifications by avoiding the high cost and the distortionary impact of corruption on public procurement, and

Enabling BIDDERS to abstain from bribing or indulging in any corrupt practice in order to secure the contract by providing assurance to them that their competitors will also abstain from bribing and other corrupt practices and the BUYER will commit to prevent corruption, in any form, by its officials by following transparent procedures.

The parties hereto hereby agree to enter into this Integrity Pact and agree as follows:

Section 1 – Commitments of the Principal

(1) The Principal commits itself to take all measures necessary to prevent corruption and to observe the following principles:-

a. No employee of the Principal, personally or through family members, will in connection with the tender for , or the execution of a contract, demand ; take a promise for or accept, for self or third person, any material or immaterial benefit which the person is not legally entitled to.

b. The Principal will, during the tender process treat all Bidder(s) with equity and reason. The Principal will in particular, before and during the tender process, provide to all Bidder(s) the same in-

formation and will not provide to any Bidder(s) confidential / additional information through which the Bidder(s) could obtain an advantage in relation to the tender process or the contract execution.

c. Principal will exclude from the process all known prejudiced persons.

(2) If the Principal obtains information on the conduct of any of its employees which is a criminal offence under the IPC/ PC Act, or if there be a substantive suspicion in this regard, the Principal will inform the Chief Vigilance Officer and in addition can initiate disciplinary actions.

Section 2 - Commitments of the Bidder(s)/ Contractor(s)

(1) The Bidder(s) / Contractor(s) commit themselves to take all measures necessary to prevent corruption. The Bidder(s) / Contractor(s) commit themselves to observe the following principles during participation in the tender process and during the contract execution.

a. The Bidder(s) / Contractor(s) will not, directly or through any other person or firm, offer, promise or give to any of the Principal's employees involved in the tender process or the execution of the contract or to any third person any material or other benefit which he/ she is not legally entitled to, in order to obtain in exchange any advantage of any kind whatsoever during the tender process or during the execution of the contract.

b. The Bidder(s) / Contractor(s) will not enter with other Bidders into any undisclosed agreement or understanding, whether formal or informal. This applies in particular to prices, specifications, certifications, subsidiary contracts, submission or non- submission of bids or any other actions to restrict competitiveness or to introduce cartelisation in the bidding process.

c. The Bidder(s) / Contractor(s) will not commit any offence under the relevant IPC/ PC Act; further the Bidder(s) / Contractor(s) will not use improperly, for purposes of competition or personal gain, or pass on to others, any information or document provided by the Principal as part of the business relationship, regarding plans, technical proposals and business details, including information contained or transmitted electronically.

d. The Bidder(s) / Contractor(s) of foreign origin shall disclose the name and address of the Agents/ representatives in India , if any, Similarly the Bidder(s) /Contractor(s) of Indian Nationality shall furnish the name and address of the foreign principals, if any. Further details as mentioned in the "Guidelines on Indian Agents of Foreign Suppliers" shall be disclosed by the Bidder(s) / Contractor(s).Further, as mentioned in the Guidelines all the payments made to the Indian agent/ representative have to be in Indian Rupees only.

e. The Bidder(s) / Contractor(s) will, when presenting their bid, disclose any and all payments made, is committed to or intends to make to agents, brokers or any other intermediaries in connection with the award of the contract.

f. Bidder(s) / Contractor(s) who have signed the Integrity Pact shall not approach the Courts while representing the matter to IEMs and shall wait for their decision in the matter.

(2) The Bidder(s) / Contractor(s) will not instigate third persons to commit offences outlined above or be an accessory to such offences.

Section 3 - Disqualification from tender process and exclusion from future contracts

If the Bidder, before contract award, has committed a transgression through a violation of Section 2 or in any other form such as to put his reliability or credibility as Bidder into question, the Principal is entitled to disqualify the Bidder from the tender process or to terminate the contract, if already signed, for such reason.

(1) If the Bidder / Contractor / Supplier has committed a transgression through a violation of Section 2 such as to put his reliability or credibility into question, the Principal is also entitled to exclude the Bidder / Contractor / Supplier from future contract award processes. The imposition and duration of the exclusion will be determined by the severity of the transgression. The severity will be determined by the circumstances of the case. In particular the number of transgressions, the position of the transgressors within the company hierarchy of the Bidder and the amount of the damage. The exclusion will be imposed for a minimum of 6 months and maximum of 3 years.

(2) A transgression is considered to have occurred if the Principal, after due consideration of available facts and evidences within his / her knowledge concludes that there is a reasonable ground to suspect violation of any commitment listed under Section 2 i.e “ Commitments of Bidder(s) / Contractor(s).

(3) The Bidder accepts and undertakes to respect and uphold the Principal’s absolute right to resort to and impose such exclusion and further accepts and undertakes not to challenge or question such exclusion on any ground, including the lack of any hearing before the decision to resort to such exclusion is taken. This undertaking is given freely and after obtaining independent legal advice.

(4) If the Bidder / Contractor / Supplier can prove that he has restored / recouped the damage caused by him and has installed a suitable corruption prevention system, the Principal may revoke the exclusion prematurely.”

Section 4 - Compensation for Damages

(1) If the Principal has disqualified the Bidder(s) from the tender process prior to the award according to Section 3, the Principal is entitled to demand and recover the damages equivalent to Earnest Money Deposit/ Bid Security.

(2) If the Principal has terminated the contract according to Section 3, or if the Principal is entitled to terminate the contract according to Section 3, the Principal shall be entitled to demand and recover from the Contractor liquidated damages of the Contract value excluding GST or the amount equivalent to Performance Bank Guarantee.

Section 5 - Previous transgression

(1) The Bidder declares that no previous transgressions occurred in the last three years with any other Company in any country conforming to the anti-corruption approach or with any Public Sector Enterprise in India that could justify his exclusion from the tender process.

(2) If the Bidder makes incorrect statement on this subject, he can be disqualified from the tender process or action can be taken as per the procedure mentioned in "Guidelines on Debarment of firms from Bidding ".

Section 6 - Equal treatment of all Bidders / Contractors / Subcontractors

(1) In case of Sub-contracting, the Principal Contractor shall take the responsibility of the adoption of Integrity Pact by the Sub-contractor.

(2) The Principal will enter into agreements with identical conditions as this one with all Bidders and Contractors.

(3) The Principal will disqualify from the tender process all bidders who do not sign this Pact or violate its provisions.

Section 7 - Criminal charges against violating Bidder(s) / Contractor(s) / Subcontractor(s)

If the Principal obtains knowledge of conduct of a Bidder, Contractor or Subcontractor, or of an employee or a representative or an associate of a Bidder, Contractor or Subcontractor which constitutes corruption, or if the Principal has substantive suspicion in this regard, the Principal will inform the same to the Chief Vigilance Officer.

Section 8 - Independent External Monitor

(1) The Principal appoints competent and credible Independent External Monitor for this Pact after approval by Central Vigilance Commission. The task of the Monitor is to review independently and objectively, whether and to what extent the parties comply with the obligations under this agreement.

(2) The Monitor is not subject to instructions by the representatives of the parties and performs his/ her functions neutrally and independently. The Monitor would have access to all Contract documents, whenever required. It will be obligatory for him / her to treat the information and documents of the Bidders/Contractors as confidential.

He/ she reports to the Chairman, Coal India Limited / CMD, Subsidiary Companies

(3) The Bidder(s) / Contractor(s) accepts that the Monitor has the right to access without restriction to all Project documentation of the Principal including that provided by the Contractor. The Contractor will also grant the Monitor, upon his/ her request and demonstration of a valid interest, unrestricted and unconditional access to their project documentation. The same is applicable to Sub-contractors.

(4) The Monitor is under contractual obligation to treat the information and documents of the Bidder(s) / Contractor(s) / Sub-contractor(s) with confidentiality. The Monitor has also signed declarations on 'Non-Disclosure of Confidential Information ' and of 'Absence of Conflict of Interest'. In case of any conflict of interest arising at a later date, the IEM shall inform Chairman, Coal India Limited / CMD, Subsidiary Companies and recuse himself / herself from that case.

(5) The Principal will provide to the Monitor sufficient information about all meetings among the parties related to the Project provided such meetings could have an impact on the contractual relations between the Principal and the Contractor. The parties offer to the Monitor the option to participate in such meetings.

(6) As soon as the Monitor notices, or believes to notice, a violation of this agreement, he/ she will so inform the Management of the Principal and request the Management to discontinue or take corrective action, or to take other relevant action. The monitor can in this regard submit non-

binding recommendations. Beyond this, the Monitor has no right to demand from the parties that they act in a specific manner, refrain from action or tolerate action.

(7) The Monitor will submit a written report to the Chairman, Coal India Limited / CMD, Subsidiary Companies within 8 to 10 weeks from the date of reference or intimation to him by the Principal and, should the occasion arise, submit proposals for correcting problematic situations.

(8) If the Monitor has reported to the Chairman, Coal India Limited / CMD, Subsidiary Companies, a substantiated suspicion of an offence under relevant IPC/ PC Act, and the Chairman, Coal India Limited / CMD, Subsidiary Companies has not, within the reasonable time taken visible action to proceed against such offence or reported it to the Chief Vigilance Officer, the Monitor may also transmit this information directly to the Central Vigilance Commissioner.

(9) The word 'Monitor' would include both singular and plural.

Section 9 - Pact Duration

This Pact begins when both parties have legally signed it. It expires for the Contractor 12 months after the last payment under the contract, and for all other Bidders 6 months after the contract has been awarded. Any violation of the same would entail disqualification of the bidders and exclusion from future business dealings.

If any claim is made / lodged during this time, the same shall be binding and continue to be valid despite the lapse of this pact as specified above, unless it is discharged / determined by Chairman Coal India Limited / CMD, Subsidiary Companies.

Section 10 - Other provisions

(1) Changes and supplements as well as termination notices need to be made in writing. Side agreements have not been made.

(2) If the Contractor is a partnership or a Joint Venture, this agreement must be signed by all partners or JV members.

(3) Should one or several provisions of this agreement turn out to be invalid, the remainder of this agreement remains valid. In this case, the parties will strive to come to an agreement to their original intentions.

(4) Issues like Warranty / Guarantee etc. shall be outside the purview of IEMs.

(5) In the event of any contradiction between the Integrity Pact and its Annexure, the Clause in the Integrity Pact will prevail.

Section 11- Facilitation of Investigation

In case of any allegation of violation of any provisions of this Pact or payment of commission, the BUYER or its agencies shall be entitled to examine all the documents including the Books of Accounts of the BIDDER and the BIDDER shall provide necessary information and documents in English and shall extend all possible help for the purpose of such examination.

Section 12- Law and Place of Jurisdiction

This Pact is subject to Indian Law. The place of performance and jurisdiction is the seat of the BUYER.

Section 13 - Other Legal Actions.

The actions stipulated in this Integrity Pact are without prejudice to any other legal action that may follow in accordance with the provisions of the extant law in force relating to any civil or criminal proceedings.

(For & On behalf of the Principal)

(For & On behalf of Bidder/ Contractor)

(Office Seal)

(Office Seal)

Place -----

Place -----

Date -----

Date -----

Witness 1:
(Name & Address)

Witness 2:
(Name & Address)

Guidelines for Indian Agents for Foreign supplier (Part of Integrity Pact)

1. Authorized Indian Agent of a foreign manufacturer or indigenous manufacturer is also eligible to quote on behalf of its principal against the tender, in case manufacturer as a matter of corporate policy does not quote directly. However, in such case, authorized Indian Agent shall have to upload scanned copy of tender specific Manufacturer's Authorization, signed and stamped by the manufacturer to quote against the CIL Tender, indicating the Tender Reference N. and date along with the offer. The authorized Indian Agent is to upload scanned copies of details in respect of its organization along with the copies of document like certificate of incorporation / registration etc. alongwith the offer. The firm (Indian Agent) should be in existence for 3 years on the date of tender opening, irrespective of date of appointment as Indian Agent.

In case an Indian Agent is participating in a tender on behalf of one manufacturer, it is not allowed to participate / quote on behalf of another manufacturer in this tender or in a parallel tender for the same item. Further, in a tender, either manufacturer can quote or its authorized Indian Agent can quote but both are not allowed to participate/ quote in the same tender. Also, one manufacturer can authorise only one agent to quote in the same tender. All the bids, not quoted as per the above guidelines, will be rejected.

2. The Foreign manufacturer must indicate the name & address of its agent in India. It should also indicate the commission payable to them and the specific services rendered by them. The Indian Agency commission will be payable only on FOB prices of goods and it should be quoted as a percentage of the FOB price. In case, the foreign manufacturer does not have any Indian Agent, it should be clearly mentioned in the bid. In terms of Integrity Pact, the Bidder has also to disclose all payments to agents, brokers or any other intermediaries. The amount of agency commission payable to Indian Agent should not exceed 5% or what is specified in agency agreement, whichever is lower.

3. In addition to above A certificate that no commission is payable by the principal supplier to any agent, broker or any other intermediary against this contract other than percentage as indicated in BOQ (not exciding 5% of FOB) of FOB value of the contract to Indian Agent. This certificate forms a part of letter of credit.

4. The payment of Indian Agency Commission, if any, involved, may be considered in case of necessity, subject to compliance of the Government of India guidelines issued from time to time. The name of the Indian Agent with their full address and the quantum of Agency commission if any, payable shall have to be mentioned in the offer by the foreign manufacturer.

The following documents shall be submitted by the Bidder in case of contract with foreign principals involving Indian agents:

a. Foreign principal's pro-forma invoice or any other authentic document indicating the commission payable to the Indian agent, nature of after sales service to be rendered by the Indian Agent and the precise relationship between the Principal and the Agent and their mutual interest

b. Copy of the agency agreement if any with the foreign principal stating the precise relationship between them and their mutual interest in the business.

However, if all the details given in Para – (i) are complied with, the requirement of submission of document mentioned at Para – (ii) may be waived.

5. Agency commission, if any, shall be paid in equivalent Indian Rupees.

Code of Integrity for Public Procurement (CIPP):

1. Introduction

Public procurement is perceived to be prone to corruption and ethical risks. To mitigate this, the officials of Procuring Entities involved in procurement and the bidders/ contractors must abide by the following Code of Integrity for Public Procurement (CIPP). All Procuring Officials shall give an undertaking to abide by the Code of Integrity of Public Procurement (CIPP) in ERP while processing PR in SAP ERP. The undertaking shall be put in format of PR itself in ERP. However, if estimate is processed outside ERP then separate undertaking in this regards shall be given by all procuring officials. The bidders/ contractors should be asked to sign a declaration about abiding by a Code of Integrity for Public Procurement (including sub-contractors engaged by them) during submission of bid, with a warning that, in case of any transgression of this code, it would be liable for punitive actions such as cancellation of contracts, banning and blacklisting or action in Competition Commission of India, and so on.

2. Code of Integrity for Public Procurement

Procuring authorities as well as bidders, contractors and consultants should observe the highest standard of ethics and should not indulge in the following prohibited practices, either directly or indirectly, at any stage during the procurement process or during execution of resultant contracts:

- i) **“Corrupt practice”**: making offers, solicitation or acceptance of bribe, rewards or gifts or any material benefit, in exchange for an unfair advantage in the procurement process or to otherwise influence the procurement process or contract execution;
- ii) **“Fraudulent practice”**: any omission or misrepresentation that may mislead or attempt to mislead so that financial or other benefits may be obtained or an obligation avoided. This includes making false declaration or providing false information for participation in a tender process or to secure a contract or in execution of the contract;
- iii) **“Anti-competitive practice”**: any collusion, bid rigging or anti-competitive arrangement, or any other practice coming under the purview of The Competition Act, 2002, between two or more bidders, with or without the knowledge of the procuring entity, that may impair the transparency, fairness and the progress of the procurement process or to establish bid prices at artificial, non-competitive levels;
- iv) **“Coercive practice”**: harming or threatening to harm, persons or their property to influence their participation in the procurement process or affect the execution of a contract;
- v) **“Conflict of interest”**: Participation by a bidding firm or any of its affiliates that are either involved in the consultancy contract to which this procurement is linked; or if they are part of more than one bid in the procurement; or if the bidding firm or their personnel have relationships or financial or business transactions with any official of procuring entity who are directly related to tender or execution process of contract; or improper use of information obtained by the (prospective) bidder from the procuring entity with an intent to gain unfair advantage in the procurement process or for personal gain.
- vi) **“Obstructive practice”**: materially impede the procuring entity’s investigation into allegations of one or more of the above mentioned prohibited practices either by deliberately destroying, falsifying, altering; or by concealing of evidence material to the investigation; or by making false statements to investigators and/ or by threatening, harassing or intimidating any party to prevent it from disclosing its knowledge of matters relevant to the investigation or from pursuing the investigation; or by impeding the procuring entity’s rights of audit or access to information;

3. Obligations for Proactive Disclosures

i) Procuring authorities as well as bidders, contractors and consultants, are obliged under Code of Integrity for Public Procurement to suo-moto proactively declares any conflicts of interest (coming under the definition mentioned above – pre-existing or as and as soon as these arise at any stage) in any procurement process or execution of contract. Failure to do so would amount to violation of this code of integrity; and

ii) Any bidder must declare, whether asked or not in a bid document, any previous transgressions of such a code of integrity with any entity in any country during the last three years or of being debarred by any other procuring entity. Failure to do so would amount to violation of this code of integrity.

iii) To encourage voluntary disclosures, such declarations would not mean automatic disqualification for the bidder making such declarations. The declared conflict of interest may be evaluated and mitigation steps, if possible, may be taken by the procuring entity. Similarly voluntary reporting of previous transgressions of Code of Integrity elsewhere may be evaluated and barring cases of various grades of debarment, an alert watch may be kept on the bidder's actions in the tender and subsequent contract.

4. Punitive Provisions

Without prejudice to and in addition to the rights of the procuring entity to other penal provisions as per the bid documents or contract, if the procuring entity comes to a conclusion that a (prospective) bidder/ contractor directly or through an agent, has violated this code of integrity in competing for the contract or in executing a contract, the procuring entity may take appropriate measures including one or more of the following:

- i) If his bids are under consideration in any procurement
 - a) Forfeiture or encashment of bid security;
 - b) calling off of any pre-contract negotiations; and
 - c) rejection and exclusion of the bidder from the procurement process
- ii) If a contract has already been awarded
 - a) Cancellation of the relevant contract and recovery of compensation for loss incurred by the procuring entity;
 - b) Forfeiture or encashment of any other security or bond relating to the procurement;
 - c) Recovery of payments including advance payments, if any, made by the procuring entity along with interest thereon at the prevailing rate;
- iii) Provisions in addition to above:
 - a) banning/ debarment of the bidder from participation in future procurements of the procuring entity for a period not less than one year;
 - b) In case of anti-competitive practices, information for further processing may be filed under a signature of concerned Director of CIL/Subsidiary, with the Competition Commission of India.
 - c) Initiation of suitable disciplinary or criminal proceedings against any individual or staff found responsible.

**PROFORMA OF BANK GUARANTEE FOR RELEASE OF RETENTION MONEY/BID SECURITY DEDUCT-
ED @5% FROM RUNNING BILL
IN LIEU OF RECEIVING PAYMENT AGAINST THE SECURITY DEPOSIT ACCRUED ANNUALLY BY PAY-
ING THE RUNNING BILL AT 95%, i.e. THE RETENTION MONEY DEDUCTED @ 5% FROM RUNNING
BILL**

To

.....

.....

Re: Bank guarantee in respect of contract No.....

Dated..... between (Name of the)

And (Name of the contractor)

WHEREAS

..... (Name and address of the Contractor) (herein after called "the Contractor") has entered into a contract dated.....(herein after called the said contract) with (name of the Company) (hereinafter called "the Company") to execute (name of the contract and brief description of work) on the terms and conditions contained in the said contract.

It has been agreed that the Contractor shall furnish a Bank Guarantee from a Schedule commercial bank (i.e. Indian or Foreign Banks included in the Second Schedule of Reserve Bank of India Act, 1934 excluding Co-operative banks or Regional Rural Banks) for a sum of Rs..... as security for release of equivalent amount of Retention Money/Bid Security as per terms and conditions of the said contract.

We..... (name of the Bank) having its branch/Office at..... have, at the request of the Contractor, agreed to furnish this bank Guarantee by way of Bid Security.

NOW, THEREFORE, we the..... Bank (herein after called The Bank) hereby, unconditionally and irrevocably, guarantees and affirms as follows:

The Bank do hereby irrevocably guarantees and unconditionally agree with the Company that if the contractor shall in any way fail to observe or perform the terms and conditions of the said contract or shall commit any breach of its obligation there under, the Bank shall on its mere first written demand, and without any objection, demur and without any reference to the contractor, pay to the company the said sum of or such portion as shall then remain due with interest without requiring the Company to have recourse to any legal remedy that may be available to it to compel the Bank to pay the sum, or failing on the company to compel such payment by the contractor.

Any such demand shall be conclusive as regards the liability of the Contractor to the Company and as regards the amount payable by the Bank under this guarantee. The Bank shall not be entitled to withhold payment on the ground that the Contractor has disputed its liability to pay or has disputed the quantum of the amount or that any arbitration proceeding or legal proceeding is pending between the Company and the Contractor regarding the claim.

The Bank further agree that the Guarantee shall come into force from the date hereof and shall remain in force and effect till the period that will be taken for the performance of the said Contract which is likely to be day of but if the period of Contract is extended either pursuant to the provisions in the said Contract or by mutual agreement between the contractor and the company, the Bank shall renew the period of the Bank Guarantee failing which it shall pay to the company the said sum of Rs..... or such lesser amount of the said sum of Rs..... as may be due to the company and as the company may demand.

This Guarantee shall remain in force until the dues of the company in respect of the said sum of Rs..... and interest are fully satisfied and the Company certifies that the Contract has been fully carried out by the Contractor and he has discharged the guarantee.

The Bank further agrees with the company that the company shall have the fullest liberty without consent of the Bank and without affecting in any way the obligations hereunder to vary any of the terms and conditions of the said contract or to extend time for performance of the said contract from time to time or to postpone for any time or from time to time any of the powers exercisable by the Company against the contractor and to forbear to enforce any of the terms & conditions relating to the said Contract and the Bank shall not be relieved from its liability by reason of such failure or extension being granted to the Contractor or to any forbearance, act or omissions on the part of the company or any indulgence by the Company to the Contractor or any other matter or thing whatsoever which under the law relating to sureties would but for this provision have the effect of relieving or discharging the Guarantor.

The Bank further agrees that in case this Guarantee is required for a longer period and it is not extended by the Bank beyond the period specified above the Bank shall pay to the company the said sum of Rs..... or such lesser sum as may then be deemed to the Company and as the Company may require.

Notwithstanding anything contained herein the liability of the Bank under this Guarantee is restricted to Rs..... The Guarantee shall remain in force till the day*..... of*..... and unless the Guarantee is renewed or claim is preferred against the Bank on or before the said date all rights of the Company under this Guarantee shall cease and the Bank shall be relieved and discharged from all liabilities hereunder except as provided in the preceding Clause.

* the date of guarantee shall cover a minimum period of one year or suitable period i.e. 90 days beyond the defect liability period whichever is more. Defect liability period shall be derived based on provisions of contract.

Any notice by way of request, demand or otherwise hereunder maybe sent by post/e-mail/Fax addressed to the bank branch/operative branch, which shall be deemed to be a sufficient demand notice. Bank shall effect payment thereof forthwith.

This Guarantee will not be discharged due to the change in the constitution of the Bank or the Contractor.

The Bank has under it is constitution power to give this guarantee and Shri who has signed it on behalf of the Bank has authority to do so.

Signed and sealed this.....day of.....at.....

SIGNED, SEALED AND DELIVERED

For and on behalf of the Bank by:

(Signature)

(Name)

(Designation)

(Code number)

(address)

“The Bank Guarantee as referred above shall be operative at our branch at..... payable at.....

(NIT shall specify town/city of the operative Branch. Bank Guarantee shall specify name of the branch with address of the specified town/city)”

NOTE:- The department shall ensure extension of guarantee period in case of extension of time.

**PROFORMA OF BANK GUARANTEE FOR PERFORMANCE
SECURITY**

To

.....

.....

Re: Bank Guarantee in respect of Contract No.....,Dated.....

Between (Name of the company) and (Name of the Contractor)

WHEREAS

..... (Name and address of the Contractor) (herein after called "the Contractor") has entered into a contract made as per letter of acceptance.....dated.....(herein after called the said contract) with (name of the Company) (hereinafter called "the Company") to execute (name of the contract and brief description of work) on the terms and conditions contained in the said contract.

It has been agreed that the Contractor shall furnish a Performance Security in the shape of Bank Guarantee from a Schedule Commercial bank (i.e. Indian or Foreign Banks included in the Second Schedule of Reserve Bank of India Act, 1934 excluding Co-operative banks or Regional Rural Banks) for a sum of Rs..... as security for due compliance and performance of the terms and conditions of the said contract.

We..... (name of the Bank) having its branch/Office at..... have, at the request of the Contractor, agreed to furnish this bank Guarantee by way of performance Security.

NOW, THEREFORE, we the..... Bank (herein after called The Bank) hereby, unconditionally and irrevocably, guarantees and affirms as follows:

The Bank do hereby irrevocably guarantees and unconditionally agree with the Company that if the contractor shall in any way fail to observe or perform the terms and conditions of the said contract or shall commit any breach of its obligation there under, the Bank shall on its mere first written demand, and without any objection, demur and without any reference to the contractor, pay to the company the said sum of or such portion as shall then remain due with interest without requiring the Company to have recourse to any legal remedy that may be available to it to compel the Bank to pay the sum, or failing on the company to compel such payment by the contractor.

Any such demand shall be conclusive as regards the liability of the Contractor to the company and as regards the amount payable by the Bank under this Guarantee. The Bank shall not be entitled to withhold payment on the ground that the Contractor has disputed its liability to pay or has disputed the quantum of the amount or that any CIL proceeding or legal proceeding is pending between the company and the Contractor regarding the claim.

The Bank further agree that the Guarantee shall come into force from the date hereof and shall remain in force and effect till the period that will be taken for the performance of the said Contract which is likely to be day of but if the period of Contract is extended either pursuant to the provisions in the said contract or by mutual agreement between the contractor and the company, the Bank shall renew the period of the Bank Guarantee failing which it shall pay to the company the said sum of or such lesser amount of the said sum of as may be due to the company and as the company may demand.

This Guarantee shall remain in force until the dues of the company in respect of the said sum ofand interest are fully satisfied and the Company certifies that the Contract has been fully carried out by the Contractor and discharged the guarantee.

The Bank further agrees with the company that the company shall have the fullest liberty without consent of the Bank and without affecting in any way the obligations hereunder to vary any of the terms and conditions of the said contract or to extend time for performance of the said contract from time to time or to postpone for any time or from time to time any of the powers exercisable by the Company against the contractor and to forebear to enforce any of the terms and conditions relating to the said Contract and the Bank shall not be relieved from its liability by reason of such failure or extension being granted to the Contractor or to any forbearance, act or omissions on the part of the company or any indulgence by the Company to the Contractor or any other matter or thing whatsoever which under the law relating to sureties would but for this provision have the effect of relieving or discharging the Guarantor.

The Bank further agrees that in case this Guarantee is required for a longer period and it is not extended by the Bank beyond the period specified above, the Bank shall pay to the company the said sum of or such lesser sum as may then be deemed to the Company and as the Company may require.

Notwithstanding anything contained herein the liability of the Bank under this Guarantee is restricted to Rs..... The guarantee shall remain in force till the day*..... of*..... and unless the guarantee is renewed or claim is preferred against the bank on or before the said date all rights of the Company under this guarantee shall cease and the Bank shall be relieved and discharged from all liabilities hereunder except as provided in the preceding Clause.

* The date of guarantee shall cover a period of "minimum one year" or "90 days beyond the date of completion" whichever is more.

Any notice by way of request, demand or otherwise hereunder maybe sent by post/e-mail/Fax addressed to the bank branch/operative branch, which shall be deemed to be a sufficient demand notice. Bank shall effect payment thereof forthwith.

This guarantee will not be discharged due to the change in the constitution of the Bank or the Contractor.

The Bank has under its constitution power to give this Guarantee and Sri..... who has signed it on behalf of the Bank has authority to do so.

Signed and sealed this.....day of.....at.....

SIGNED, SEALED AND DELIVERED

For and on behalf of the Bank by:

(Signature)

(Name)

(Designation)

(Code number)

(address)

"The Bank Guarantee as referred above shall be operative at our branch at..... payable at....."

(NIT shall specify town/city of the operative Branch. Bank Guarantee shall specify name of the branch with address of the specified town/city)"

NOTE:- The department shall ensure extension of guarantee period in case of extension of time.

PROFORMA OF JOINT VENTURE AGREEMENT

(On Non-Judicial Stamp paper of appropriate value as per provision of the Stamp Act applicable in the concerned state)

This Joint Venture agreement is made on thisday of.....

AMONGST/BETWEEN

M/s....., having its registered Office at
Represented by Shri.....(Name and Designation) of M/s.....Who has power of Attorney to enter into Joint Venture with.....andSign all documents/agreements on behalf of M/s..... (hereinafter referred to as”.....”)

AND

M/s....., having its registered Office at
Represented by Shri.....(Name and Designation) of M/s.....who has power of Attorney to enter into Joint Venture with.....andSign all documents/agreements on behalf of M/s..... (hereinafter referred to as”.....”).

AND

M/s....., having its registered Office at
Represented by Shri.....(Name and Designation) of M/s.....who has power of Attorney to enter into Joint Venture with.....andSign all documents/agreements on behalf of M/s..... (hereinafter referred to as”.....”).

The expressions M/sand M/s.....and M/sshall, wherever the context admits, mean and include their respective legal representatives, successors-in-interest and assigns and shall collectively be referred to as “Joint Venture /Parties” and individually as “Joint Venture Partner/Party”.

WHEREAS M/s.....and M/s.....agreed to form a Joint Venture in order to join their forces to obtain best results from the combinations of their individual resources of technical and management skill, finance and equipment for the benefit of the project and in order to submit the Bid for the work of “
..... (Hereinafter referred to as “Project”) under.....(Name of Company(hereinafter referred to as “the principle Employer”).

The Parties hereby enter into this Joint Venture Agreement (hereinafter referred to as “Joint Venture agreement”) to jointly prepare and submit the Bid for the Project and in the event of securing the Project from the Employer, to execute the Project in accordance with the Contract terms and conditions, to the satisfaction of the Principal Employer.

NOW THEREFORE, the parties, in consideration of the mutual premises contained herein, agree as follows:

1) FORMATION AND TERMINATION OF THE JOINT VENTURE.

The parties under this Agreement have decided to form a Joint Venture to submit the Bid for the above Project and execute the Contract with the Principal Employer for the Project, if qualified and awarded.

- a) The name and style of the Joint Venture shall be “” (hereinafter called the “Joint Venture ”)
- b) The Head Office of the Joint Venture shall be located at..... and the site office will be located at the site of the Project. All communication regarding the project will be made to..... Telephone Nos.....
- c) Neither of the parties of the Joint Venture shall be allowed to sign, pledge, sell or otherwise dispose all or part of its respective interests in the Joint Venture to any party including the existing partner of the Joint Venture.
- d) The terms of the Joint Venture shall begin as on the date first set forth above and shall terminate on the earliest of the following dates.
 - i) The Joint Venture fails to obtain qualification from the Employer.
 - ii) The Contract for the Project is not awarded to the Joint Venture.
 - iii) The Employer cancels the Project.
 - iv) The Project is completed including defects liability period to the satisfaction of the Employer and all the parties complete any and all duties, liabilities and responsibilities under or in connection with the Contract and the Joint Venture agreement.

2) LEAD PARTNER.

M/s..... shall be the Lead Partner of the Joint Venture and is In-charge for performing the contract management. M/s..... shall be attorney of the parties duly authorized to incur liabilities and receive instructions for and on behalf of any and all partners in the Joint Venture and also all the partners of the Joint Venture shall be jointly and severally liable during the bidding process and for the execution of the contract as per contract terms with the employer in accordance with the power of attorney annexed. All Joint Venture partners M/s.....; M/s.....& M/s..... nominate and authorize Shri..... (name and designation) of M/s..... to sign all letters, correspondence, papers & certificates and to submit the Pre-qualification Application / Bid documents for and on behalf of the Joint Venture.

3) REPRESENTATIVE OF THE PARTNERS OF THE JOINT VENTURE.

Each constituent party of the Joint Venture appoints the following personnel as the representative of the relevant party with full power of attorney from the Board of Directors of the concerned company, or from the partners of the entity, or from the proprietor.

<u>JV Partner</u>	<u>Name</u>	<u>Position in the respective Company</u>
M/s.....
M/s.....
M/s

4) PARTICIPATION SHARE & WORK RESPONSIBILITIES.

4.1 The parties agree that their respective participation share (hereinafter called 'Participation Share') in the Joint Venture shall be as follows:

M/s..... :% (.....per cent)
M/s..... :% (.....per cent) and
M/s..... :% (.....per cent)

4.2 The Parties shall share the rights and obligations, risk, cost and expenses, working capitals, profits or losses or others arising out of or in relation to execution of the Project individually or collectively.

4.3 The parties shall jointly execute the works under the Project as an integrated entity and allocate responsibilities as regards division of work between themselves by organizing the adequate resources for successful completion of the Project. However all parties shall remain jointly and severally responsible for the satisfactory execution of the Project in accordance with the Contract terms and conditions.

5) JOINT AND SEVERAL LIABILITIES.

All partner of Joint Venture shall be liable jointly and severally during the Pre-qualification and Bidding process; and in the event the contract is awarded, during the execution of the Contract, in accordance with Contract terms.

6) WORKING CAPITAL

During the execution of work/service, the requirement of Working Capital shall be met individually or collectively by the JV partners.

7) BID SECURITY:

Bid Security, Performance Security and other securities shall be paid by the Joint Venture except as otherwise agreed.

8) PERSONNEL & EQUIPMENT

Team of Managers / Engineers of all the partners of the Joint Venture will form part of the core management structure and assist in execution of the project. The list of Personnel and equipment proposed to be engaged for the project by each Party will be decided by the management committee.

9) NON PERFORMANCE OF RESPONSIBILITY BY ANY PARTY OF JOINT VENTURE .

- a) As between themselves, each Party shall be fully responsible for the fulfillment of all obligations arising out of its scope of the work for the Project to be clarified subject to the Agreement between the Parties and shall hold harmless and indemnified against any damage arising from its default or non-fulfillment of such obligations.
- b) If any Party fails to perform its obligations described in this Agreement during the execution of the Project and to cure such breach within the period designated by the non-defaulting

party, then the other party shall have the right to take up work, the interest and responsibilities of the defaulting party at the cost of the defaulting party.

- c) Stepping into the shoes of the existing partner of Joint Venture with all the liabilities of the existing partner from the beginning of the contract with the prior approval of CIL/Subsidiary.
- d) Notwithstanding demarcation or allotment of work of between/amongst Joint Venture partners, Joint Venture shall be liable for non-performance of the whole contract irrespective of their demarcation or share of work.
- e) In case bid being accepted by Company, the payments under the contract shall only be made to the Joint Venture and not to the individual partners.

10) BANK A/C.

Separate Bank A/c. shall be opened in the name of the Joint Venture in a scheduled or Nationalized Bank in India as per mutual Agreement and all payments due to the Joint Venture shall be received only in that account, which shall be operated jointly by the representative of the Parties hereto. The financial obligations of the Joint Venture shall be discharged through the said Joint Venture Bank Account only and also all the payments received or paid by company to the Joint Venture shall be through that account alone.

11) LIMIT OF JOINT VENTURE ACTIVITIES.

The Joint Venture activities are limited to the bidding and in case of award, to the performance of the Contract for the Project according to the conditions of the Contract with the Employer.

12) TAXES.

Each Party shall be responsible for its own taxes, duties and other levies to be imposed on each party in connection with the Project. The taxes, duties and other levies imposed on the Joint Venture in connection with the Project shall be paid from the account of the Joint Venture.

13) EXCLUSIVITY

The Parties hereto agree and undertake that they shall not directly or indirectly either individually or with other party or parties take part in the Bid for the said Project. Each Party further guarantee to the other party hereto that this undertaking shall also apply to its subsidiaries and companies under its direct or indirect control.

14) MISCELLANEOUS:

- a. Neither party of the Joint Venture shall assign, pledge, sell or otherwise dispose all or part of its respective interests in the Joint Venture to all third party without the Agreement of the other party in writing.
- b. Subject to the above clause, the terms and conditions of this agreement shall be binding upon the parties, the Directors, Officers, Employees, Successors, Assigns and Representatives.

15) APPLICABLE LAW

This agreement shall be interpreted under laws and regulations of India.

IN WITNESS Whereof the Parties hereto have hereunder set their respective hands and seals the day, month, year first above written.

For

For.....

Signature _____
(Name & Address)

Signature _____
(Name & Address)

(Official Seal)

(Official Seal)

Place

Place.....

Date

Date

Witness
Signature

Witness
Signature

(Name & Address)

(Name & Address)

MANDATE FORM FOR ELECTRONIC FUND TRANSFER / INTERNET BANKING PAYMENT.

1. Name of the Bidder :.....

2. Address of the Bidder :

.....
 City..... Pin Code.....
 E-mail Id
 Permanent Account Number

3. Particulars of Bank:

Bank Name		Branch Name	
Branch Place		Branch City	
Pin Code		Branch Code	
MICR No.			
(Digital Code number appearing on the MICR Band of the cheque supplied by the Bank. Please attach Xerox copy of a cheque of your Bank for ensuring accuracy of the Bank Name, Branch Name and Code Number.			
RTGS CODE			
Account Type	Savings	Current	Cash Credit
Account Number(as appearing in the Cheque Book.			

4. Date from which the mandate should be effective.

I hereby declare that the particulars given above are correct and complete. If any transaction is delayed or not effected for reasons of incomplete or incorrect information. I shall not hold Company responsible. I also undertake to advise any change in the particulars of my account to facilitate updation of records for purpose of credit of amount through NEFT/ RTGS transfer. I agree to discharge responsibility expected of me as a participant under the scheme. Any bank charges levied by the bank for such e-transfer shall be borne by us.

Place :

Date:

Signature of the Party / Authorised Signatory

 Certified that particulars furnished above are correct as per our records.

Banker's Stamp

Date

Signature of the Authorised official from the Bank

INVITATION AND DECLARATION FOR NEGOTIATIONS.

(Refer Para 5.6.6 (iv) (c))

Invitation for Negotiations

(On letterhead of the procuring entity)

No: _____ Dt: _____

To M/ s _____ Registered A/ D

Sub: Tender No ----- opened on -----for the supply of -----

Dear Sir,

The rates quoted in your tender are considered high. You are therefore, requested to come for negotiations of rates, on..... (date) at..... (time) at..... (venue).

You should, however, come for negotiations only in case you are prepared to furnish before such date the declaration appended herewith.

A copy of the form in which you may submit your revised offer after negotiations is enclosed.

Yours faithfully,

Enclosure:

(Authorised Officer)

- (1) Form of Declaration
- (2) Form of Revised Offer

FORM OF DECLARATION

(To be signed and submitted before start of negotiations)

(On company letterhead)

No: _____ Dt: _____

To _____

Sub: Tender No ----- Opened on -----for the supply of -----

Ref: Your invitation for negotiations No: dated:

Dear Sir,

I _____ duly authorised on behalf of M/ s. _____ do declare that in the event of failure of the contemplated negotiations relating to Tender No. _____ opened on _____ my original tender shall remain open for acceptance on its original terms and conditions.

Yours faithfully,

Place: _____

Date: _____

Signatures of bidder, or officer authorised to sign the bid documents on behalf of the bidder

FORMAT OF REVISED OFFER IN NEGOTIATIONS.

(Refer Para 5.6.6(iv) (d))

Revised Offer in Negotiations

(On company letterhead)

From.....

Full address.....

To

Sir,

Sub: Tender No ----- opened on -----for the supply of -----

Ref: Your invitation for negotiations no: dated:

1. On further discussions with your representatives onin response to your letter no dated

We are not prepared to reduce the rates already quoted in the original tender, which will remain valid up to.....

Or

1. I/ we reduce my/ our rates as shown in the enclosed schedule of items.

2. I/ we am/ are aware that the provisions of the original bidding document remain valid and binding on me.

3. I/ we undertake to execute the contract as per following Schedule.....

4. I/ we agree to abide by this tender on the revised rate quoted by me/ us, it is open for acceptance for a period of 120/ 180 days from this date, *i. e.*, up to and in default of my/ our doing so, I/ we will forfeit the earnest money deposited with the original tender/ attached herewith. Eligibility as valid tenderers shall be deemed to be the consideration for the said forfeiture.

Yours faithfully,

Signatures of bidder or
Officer authorised to sign the bid
documents on behalf of the bidder

SAMPLE FORM FOR SITE ORDERS BOOK / HINDRANCE REGISTER.

Name of Work:

Date of Commencement:

Period of Completion:

Sl. No.	Remarks of the Inspecting Officer or contractor.	Action Taken and by whom	Remarks
1	2	3	4